

VTT Technical Research Centre of Finland

## Life assessment and maintenance of welded piping operating at high temperatures

Pohja, Rami; Tuurna, Satu; Hakala, Timo J.; Auerkari, Pertti; McNiven, Ulla; Laaksonen, Leila; Nikkarila, Reino

*Published in:*  
Baltica XI

Published: 01/01/2019

*Document Version*  
Publisher's final version

[Link to publication](#)

*Please cite the original version:*

Pohja, R., Tuurna, S., Hakala, T. J., Auerkari, P., McNiven, U., Laaksonen, L., & Nikkarila, R. (2019). Life assessment and maintenance of welded piping operating at high temperatures. In *Baltica XI: International Conference on Life Management and Maintenance for Power Plants* VTT Technical Research Centre of Finland.



VTT  
<http://www.vtt.fi>  
P.O. box 1000FI-02044 VTT  
Finland

By using VTT's Research Information Portal you are bound by the following Terms & Conditions.

I have read and I understand the following statement:

This document is protected by copyright and other intellectual property rights, and duplication or sale of all or part of any of this document is not permitted, except duplication for research use or educational purposes in electronic or print form. You must obtain permission for any other use. Electronic or print copies may not be offered for sale.

# Life assessment and maintenance of welded piping operating at high temperatures

Rami Pohja<sup>1</sup>, Satu Tuurna<sup>1</sup>, Timo Hakala<sup>1</sup>, Pertti Auerkari<sup>1</sup>, Ulla McNiven<sup>2</sup>, Leila Laaksonen<sup>2</sup>, Reino Nikkarila<sup>3</sup>

<sup>1</sup>VTT Technical Research Centre of Finland Ltd  
Espoo and Tampere, Finland

<sup>2</sup>Fortum eNext, Fortum Power and Heat Oy  
Jyväskylä and Naantali, Finland

<sup>3</sup>Replico  
Majavesi, Finland

## Abstract

Well before the end of life, the condition of aging hot end components will be of repeated interest in operating thermal power and process plants. At their severe service environments, the components will by design face a combination of life-limiting degradation mechanisms, such as creep and fatigue. With likely deviations in the initial geometry, material condition and service history from the assumptions made in design, in-service inspections and adjustment according to the results can help to avoid suboptimal operation and maintenance. Increasing grid fluctuation due to intermittent wind power may strain the production capacity covering for the gaps created by periods of unavailable renewables. The impact is modest as long as the gaps are covered by flexible options such as spinning reserves and hydro power, but increasing needs and reducing reserves could result in shortening equipment life, e.g. at locations of strong thermal transients. In countries with high share of renewables, there is often a shift to capacity that responds faster in cycling service than older steam plants, and also emit less CO<sub>2</sub>. In Finland, significant reduction to CO<sub>2</sub> emissions is expected from new nuclear capacity that would however not help much in supply fluctuation. Further flexible production will be therefore needed, as more wind power will be added.

## 1. Introduction

Welded high temperature piping (Figure 1) is used in thermal power plants and many other process plants to transport the energy carrier medium from the heat sources to points of consumption or conversion. The health and performance of such pipework will significantly contribute to the reliability and economy of operation that is today rarely punctuated by unplanned interruptions. Nevertheless, hot pipework is designed for finite life and will experience ageing in service. It will therefore need occasional attention to where, when and how the ageing will limit life, and how to appropriately respond to it. Life will be consumed at the highest rate at critical locations such as welded joints with the most adverse combination of materials properties, temperature and loading history. Both such combinations and the resulting damage will inevitably deviate to some extent from those assumed in design, and therefore the actual life and the limiting locations may differ from the rather approximate assumptions of the (minimum) design life. The well-established approach is

then to try adjusting the assumed or predicted life, and plans on future actions, according to the available information on component and material characteristics, service history, and observations. Updating will be necessary at times, as the service history will evolve with new information from inspections and maintenance, including possible repairs, replacements or modifications [1,2]. In practice it is essential to find the areas of maximum damage, as these will determine the locations and timing to inspect and finally to repair or replace components before failure or unplanned outage. The expected locations of interest may change in time, not only because of obvious reasons such as implemented repairs and component replacements, but also due to possible changes in operation. In particular, such changes may arise in the demand enforcing more frequent cycling, i.e. more numerous start-ups/shutdowns, in response to increasing share of intermittent supply in the grid.

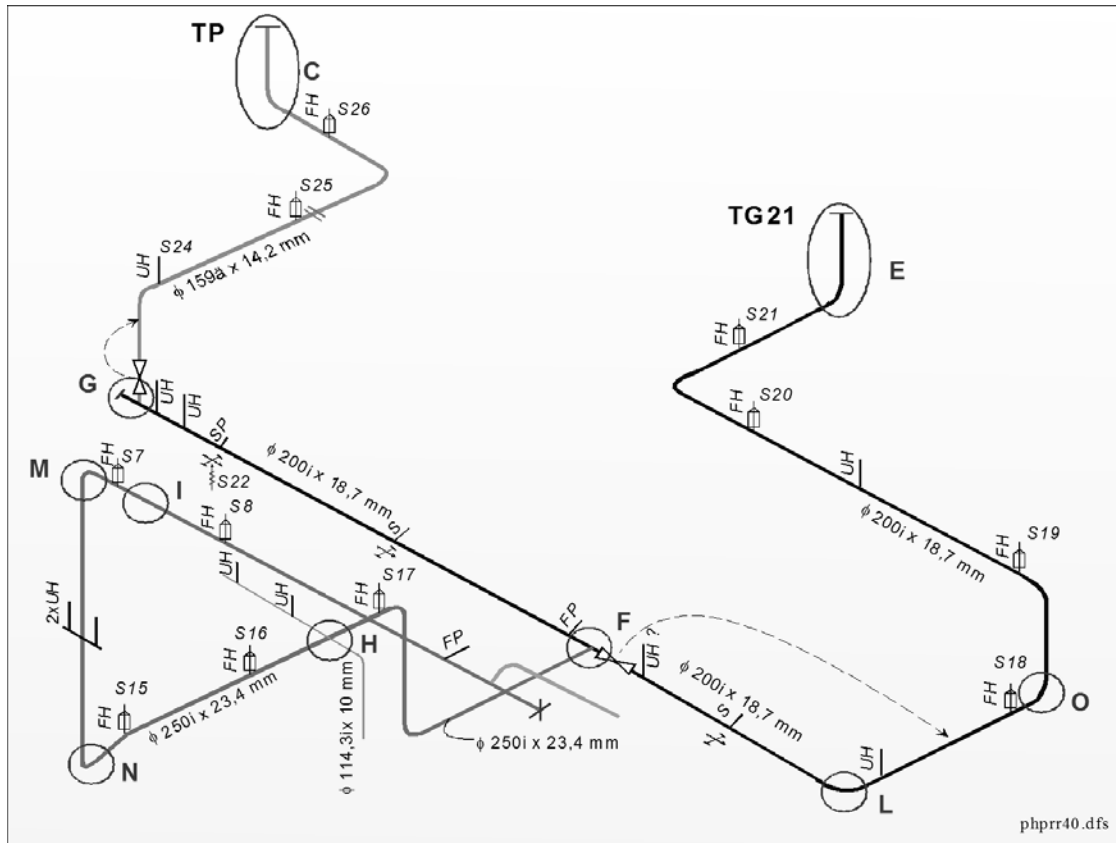

**Figure 1.** A section of the main steam pipework of a medium-size power plant, with letters in bold indicating areas of potential interest for inspections

## 2. Adaptation to climate policies: Impact of increased cycling

The supply from renewables such as wind is today fairly predictable in short term, but remains very variable in availability (Figure 2a). As the capacity of wind power increases in northern Europe, the fluctuation is stressing the complementing plants. To the extent that this will apply to thermal units, it may significantly reduce the available time in service, i.e. life of high temperature components that were not designed for such cyclic and ramping operation. Additional challenges can arise from the simultaneous drive to reduce fossil capacity in general, and to introduce large units that are efficient in base load but less ideal for load-follow or cyclic operation.

In Finland, the challenge from fluctuating supply is not yet as urgent as in some other regions in Europe, mainly because the share of wind power is still modest, about 7% of the production in 2018, and the current solar capacity remains marginal. Fluctuation in such a modest level is reasonably supported by spinning and other reserves, hydro capacity and imports. Power import remains high particularly during the coldest winter season (Figure 2b), although it is expected to decrease with new capacity entering service. Aligned with the

climate policies to reduce emissions, the new capacity would mainly consist of wind, biomass or waste firing, and nuclear, while fossil supply keeps winding down. The impact from renewables will be more pronounced after this trend has proceeded further in the national electricity supply (Figure 3). Depending on the scenario, the renewables excluding hydro and biomass could provide up to about 50% of the total by 2050. Such a strong transformation would require much adaptation to manage the risk of grid disturbance, and could be at least as challenging for technology as for the economy of the solutions [3-5].

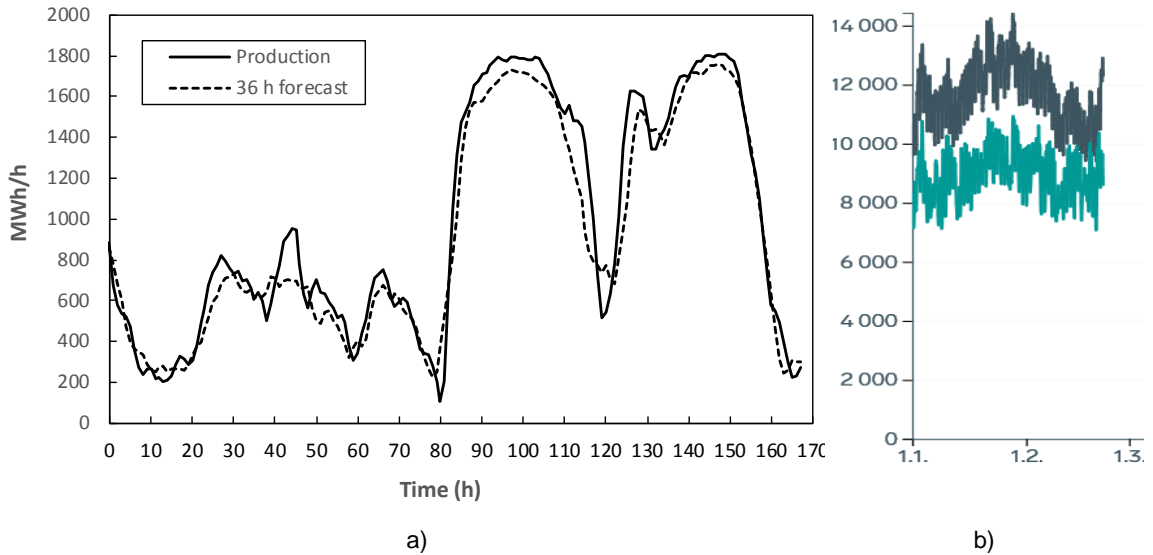

**Figure 2.** a) Wind power supply (week 7, 2019) varies from near zero to about 20% of the daytime (winter) power production; b) power (MWe) consumption (black) and production (green) during the coldest season [3].

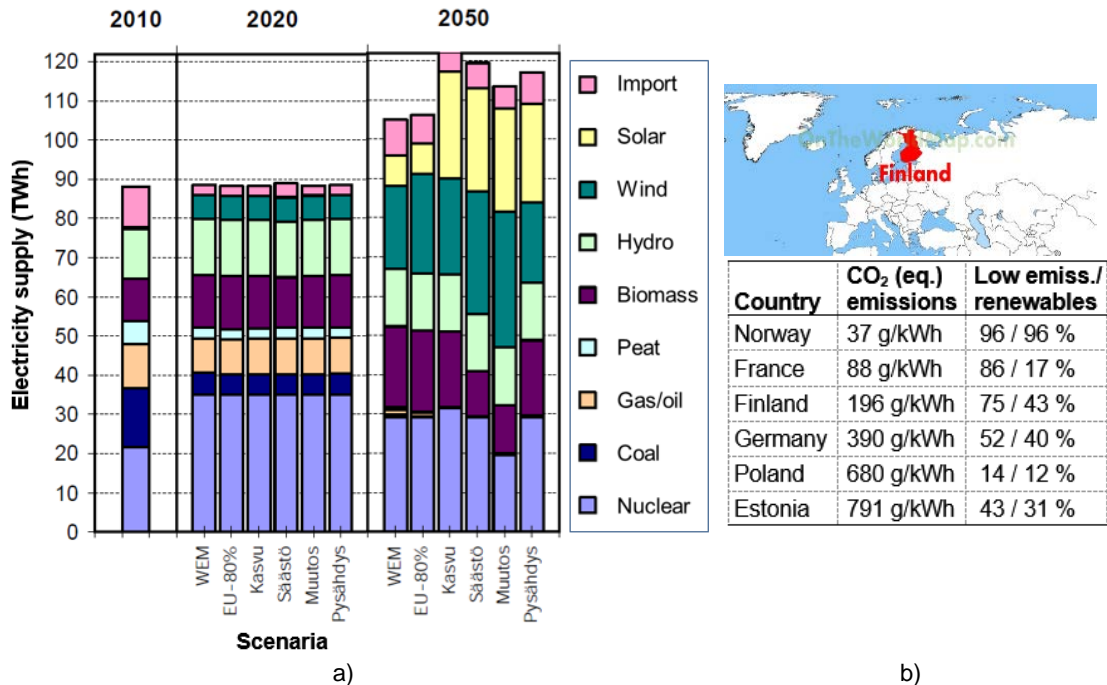

**Figure 3.** a) Foreseen electricity supply in Finland by sourcing [4]; two first scenaria (WEM, EU-80%) represent conventional climate policies, next four alternatives more ambitious emphasis on renewables; b) examples of emission levels and share of low emission/renewable sources in electricity production [5].

### **3. Impact of plant technology, including materials**

Flexibility of production is expected to increase its relative value with the growing need to efficiently cover for the grid fluctuation. It is not trivial to accommodate flexibility to the existing steam units with thick-wall components that can set stringent limits to the acceptable thermal transients. Such components include for example the steam chest and other large valve bodies of the boiler and turbine ends of the steam pipework. The response can be faster if the fluctuation is within the ranges of spinning reserves, or relies on gas turbines, gas engines, or hydro capacity. Further options to the current alternatives would benefit from improvements or new technology, particularly in regions with limited access to hydro, gas or comparable backup resources. In case of thermal plants, support to flexibility may arise for example when arrangements can be made to avoid other than hot starts by limiting the cooling between the periods of operation.

In practice, significant stresses and strains, and therefore evolving damage, will eventually appear at locations of geometric and material transients such as nozzles, notches and welds. Considering the high temperature end of the plant, most cyclic stresses may arise from the responses to the thermal transients, and hence benefits can be expected from low and compatible values of the coefficient of thermal expansion in addition to good levels of material strength and ductility/toughness under the appropriate loading conditions. For steam piping, ferritic steels remain the materials of choice, in spite of some ambition towards nickel alloys with increased operating pressures and temperatures from the currently highest levels of about 300 bar / 600-620°C. In Finland and also elsewhere, the trend has been rather the opposite, as a result of the corrosive renewable and mixed fuels on the boiler internals. Regardless of the material group, higher material strength could allow for thinner wall sections and lower stresses from thermal transients. However, increasing strength may accompany reduced ductility and increased propensity to develop in-service damage, and this can apply both to short-term and long-term (creep) properties. For example, the principle of developing high strength alloys by adding ingredients and processing for precipitation strengthening can result in materials with low ductility, if e.g. fabrication or ageing will produce narrow channels or internal surfaces where the in-service strains will concentrate. This has been a relatively common if not inevitable consequence when adding for example small amounts of strong carbide or carbonitride formers such as V, W, Nb and/or Ta to plain low-alloy or higher alloy Cr-Mo and Cr-Ni(-Mo) steels that mostly exhibit modest strength and fair ductility. There remains interest in strengthening or optimising the properties of the current high temperature steels without compromising creep ductility.

### **4. Life assessment – In-service experience vs. design**

Until recently, many thermal power plants have enjoyed relatively steady base load operation in CHP mode supported by district heating or industrial steaming services, with expected creep-dominated life for the high temperature piping. The heat affected zones (HAZ) of welds are common critical locations for creep damage in ferritic steels. The damage appears at a material-dependent rate as creep cavities forming in the HAZ, first in apparently scattered pattern with gradually increasing density, linking to form chains and finally cracks that produce the fracture surface [15]. Figure 4 shows examples of in-service creep damage in the HAZ of ferritic steels, in the form of scattered and orientated creep cavities.

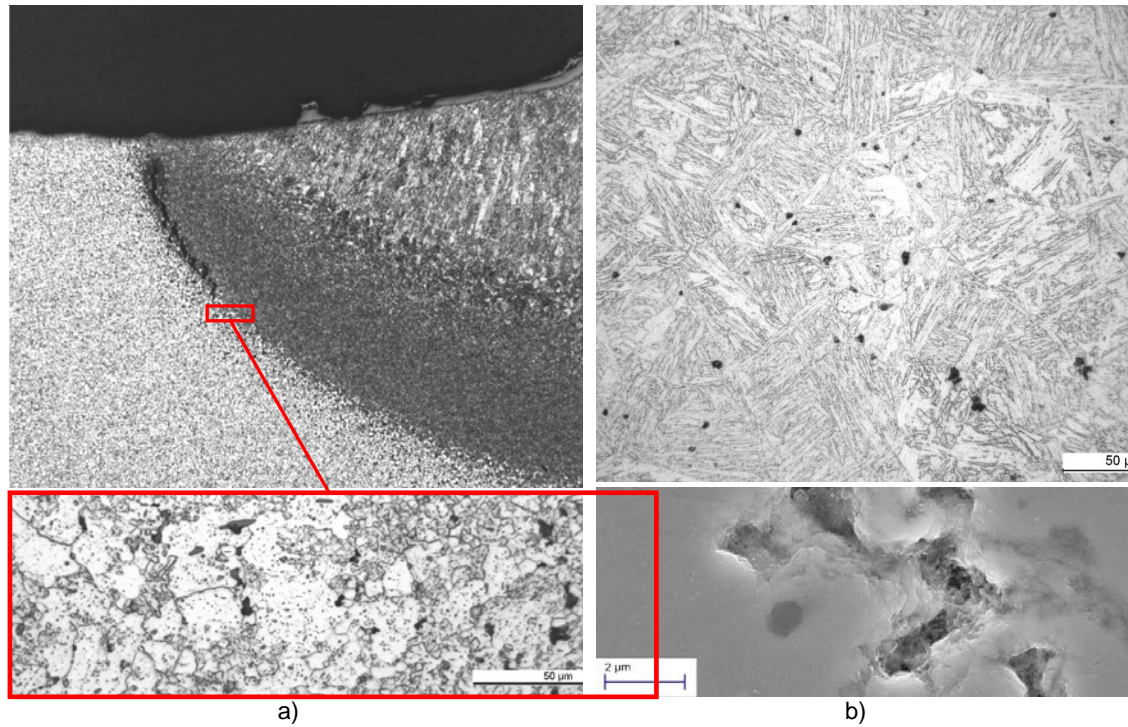

**Figure 4.** In-service creep damage in a) welded low-alloy steel; b) heat affected zone of X20CrMoV11-1

When appropriate measurements are available, creep-dominated damage in pipework can be assessed by strain-based comparison to specified strain limits, e.g.  $\epsilon_c = 0.1\%$  to  $2\%$ . This kind of approach is described in e.g. TRD 508. Another approach is the comparison to graded damage scales of creep cavitation and cracking [15]. Replica inspections are often used for such damage characterization in combination with other NDT techniques, such as PT, MT and UT.

For those plants that will feel the impact from increased cycling and ramping, combined damage of creep and fatigue may emerge. Current standards, design codes and assessment procedures, such as EN 12952-4 [6], EN 13480-3 [7], EN 13445-3 [10], RCC-MRx [9] and ASME III NH [8], assess the combined creep and fatigue damage  $D_R$  as its summed creep ( $D_c$ ) and fatigue ( $D_f$ ) damage components that are interpreted as the corresponding linear life fractions (see Figure 5). The assessment procedures usually follow the inverse design approach to calculate the total damage, and tend to predict (overly) conservative life. Figure 5 also presents creep-fatigue test results for P91 steel. As in this case, typical laboratory experiments include relatively short fatigue cycles with elevated stresses and strains, and therefore represent fatigue dominated damage with much shorter periods of hold (steady service) than in actual plant operation. In life assessment, the differences in the cycles will complicate extrapolation from laboratory test results towards the in-service conditions of the plant. In simple cases the classical linear life fraction rule [6-10] may assume that the life-limiting cycles for combined creep and fatigue damage are approximately of similar type for the leading location of the leading component. Then at the limit state such as failure or damage initiation, after time  $t$  and number of cycles  $N$  under given operating conditions, and with corresponding limit values  $t_R$  and  $N_R$  under the same conditions, after summing for all relevant conditions,

$$\sum(t/t_R) + \sum(N/N_R) = D_c + D_f = D_R \quad (1),$$

where the combined damage factor  $D_R \leq 1$  at the critical or limiting state of in-service damage. A further simplification assumes that a single cycle type, for example from characteristic cold start to shutdown, dominates the life-limiting cycles. Multiplying equation (1) by  $t_R$ , we can take  $t_R D_R = L$  to represent equivalent creep life for these fixed conditions, and  $C = t_R/N_R \gg 1$  [h/cycle] as a characteristic ratio of rupture time to number of cycles to failure under the same conditions. Then the time to the critical state

$$t = L - C \cdot N \quad (2).$$

Here the ramping factor  $C$  will depend on cycle details, and typically increases for stronger transients, for example is larger for cycles with cold starts than with hot starts. For a piping, the limiting value could arise from the thermal cycle of some thick-wall component such as a valve body at the steam turbine. Combined life consumption is in principle tractable, when the significant cycles can be reasonably classified into bins of indicated or calculable levels of temperature and stress both for steady operation and transients.

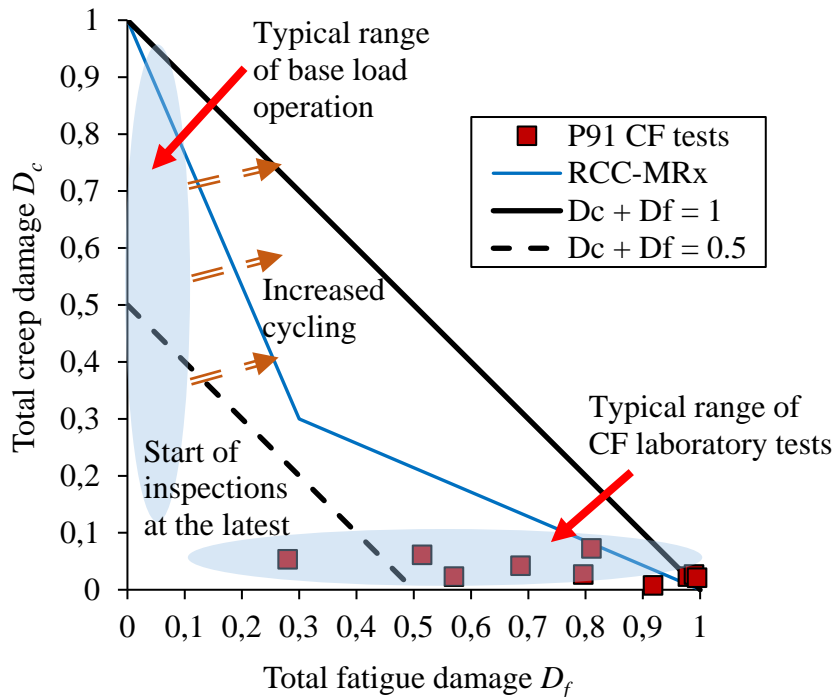

**Figure 5.** Creep-fatigue (CF) interaction diagram and CF test results of P91 (X10CrMoVNb9-1) steel, assessed using time fractions for  $D_c$ , in comparison to selected limit lines indicated by codes/standards

When the actual operating cycles start to differ from the assumed characteristics, e.g. due to more frequent cycles and/or more abrupt ramping, the damage modifies its character towards more fatigue dominated damage. In practice the resulting damage may develop faster, requiring inspections earlier than normally expected, and possibly need for re-inspections, repairs and renewal more frequently than foreseen in the design. Experience from inspection statistics can help to set the  $D_R$  limits that however will tend to decrease with more intensive cycling (Figure 2). A comparable challenge may also arise when introducing new structural materials or process modifications to an existing plant. In principle, even in such cases the approach of eq. (2) may work, provided that the characteristic cycles can be established for useful correlations to the accumulating damage and life consumption. Much of the conventional approach to assessing the accumulating damage relies on off-line monitoring, i.e. inspections. When in doubt, useful supporting data could be sought from on-line monitoring of strain/displacement or crack growth.

Note that the linear life fraction rule of eq. (1) is approximate only and should not be overextended for very variable cycles. One reason is that the actual life can differ after two cycles depending on their order. Nevertheless, the rule is widely used when the cycle characteristics remain reasonably comparable. When the required data are available, more accurate prediction can be attempted by e.g. by adopting specific principles of cycle counting [4] and/or using the approach of ductility exhaustion [11,12]. More detailed assessment methods tend to require more data on materials, geometric details, and status of the component. This is also the case when assessing the life of components with existing or postulated defects [11,13]. While in general the optimal process economy will require finite life of the critical equipment, conventional solutions tend to rely on routines that do not produce too many surprises. This may not apply when seeking competitive edge by introducing new processes, technology or other changes in the operating environment. In a small country, new large-scale combustion units are less likely, so in this sense not too many surprises for life management and maintenance are expected.

## 5. Maintenance: Inspect, run, repair or replace

Optimal inspections would avoid as much as possible unnecessary review of locations where not much is happening, and on the other hand aim to find and characterize the relevant damage. Inspections and revised life assessment can be supported by in-service analysis with updated geometry and in-service loading (Figures 6-8).

Further support for pipework inspections can be found from the evaluated damage (strain, creep cavitation/cracking), taking into account material-specific features, indications of damage initiation (depending on age, service history, resolution of equipment), indications of damage growth in terms of spatial, temporal and (possibly) interaction characteristics; and the assessed locally expired life fraction.

Risk-based inspection (RBI) aims to establish the scope and timing of inspections based on the evaluated risk (Figure 6b). With the systematic treatise, RBI can help to optimize targeting of inspections and maintenance, and to use added freedoms allowed by regulatory options when these are available. Although RBI is more commonly applied in chemical industry for large systems of clear safety hazards, in power plants suitable applications of RBI can be found in the high-energy piping and pressure vessels. The practices vary between national or company traditions, but the opportunity to wider application is supported by the globally increasing acceptance by national regulatory bodies and standardization for RBI [11-13].

The implemented RBI systems, while possibly appearing initially somewhat tedious, are likely to carry distinct benefits in justified scope of inspections and maintenance, in learning from the systematic risk-based treatment of components, and in improved opportunities for knowledge transfer within the personnel on the accumulating experience of the plant systems and critical components.

The implemented RBI application exercise on the main steam line of a CHP plant appeared to confirm the expectations: the inspection planning and other action can be given systematic justification based on risk ranking provided by RBI. The limited first application to the steam system cannot show all other benefits from longer term RBI experience, but there seems to be no particular reason either not to expect them. The observations of the type IV creep damage of a welded branch after more than 200 000 h of service (Figures 4b and 6a) seem to confirm the generally reasonably good and creep ductile behaviour of welded steel X20CrMoV11-1, and even in this case the specified weld repair was conducted within the planned outage.



a)

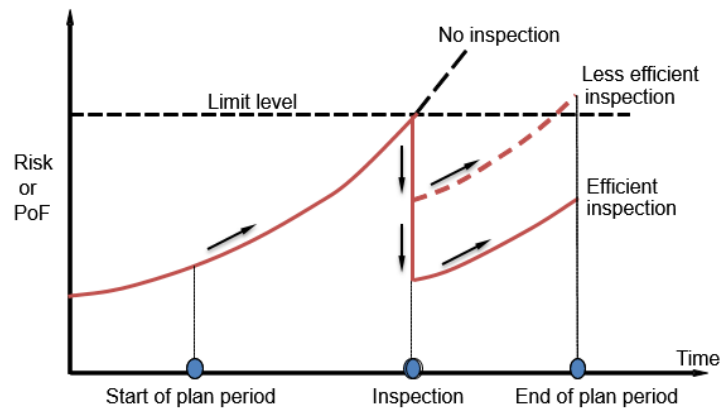

b)

**Figure 6.** a) Inspecting an X20 steam line component after repair welding; b) principles of implementing risk-based (or risk-informed) inspections: both the selected risk policy (limit) and inspection performance will affect the expected minimum life, i.e. time to next inspection [14-19]



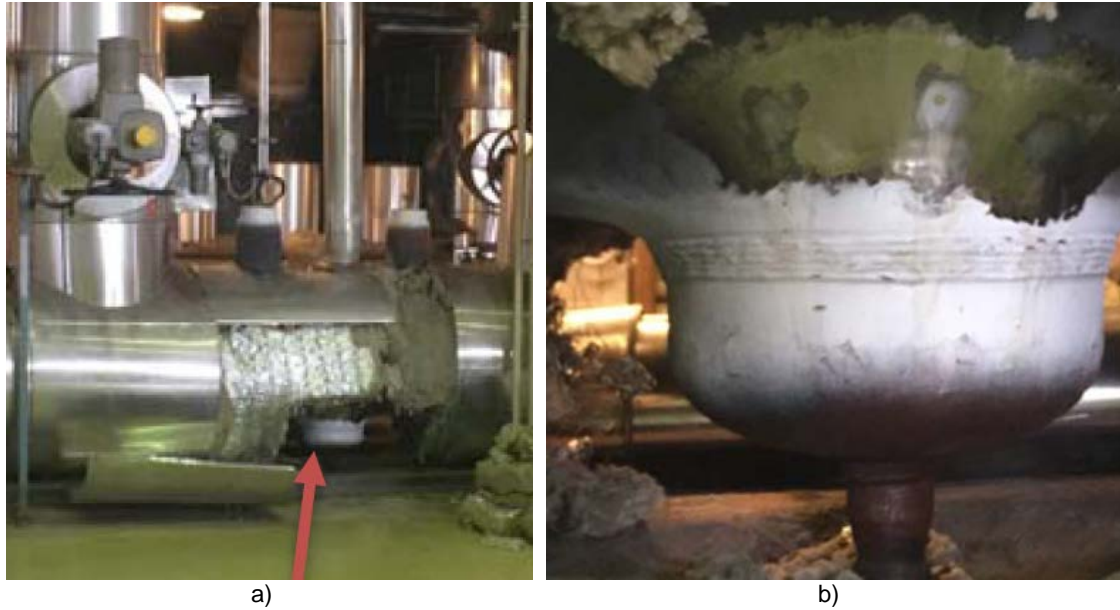

**Figure 7.** a) An opened section of a 600 mm steam header, with an arrow pointing to a drain branch under the header; b) a close-up of the drain branch for inspection after 290000 h of service

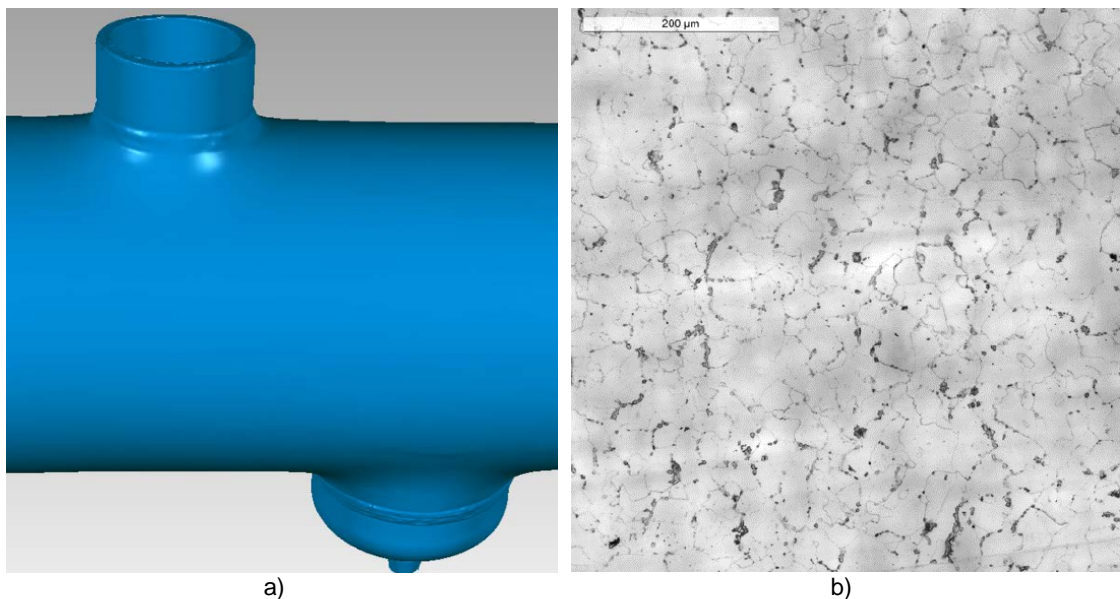

**Figure 8.** a) A partial scan of the header, with a nozzle on top and a drain branch at the bottom; b) base material creep damage on the header side of the drain branch

## 6. Conclusions and summary

The conventional experience with high temperature pipework of power and process plants largely concerns operation and maintenance of base load plants that will experience only small to modest impact from cycling. In Finland this stems from the need for wintertime district heating in cities and other population centres, and steady flow of process steam and power in the industry, loads that do not fluctuate much over time.

However, increasing fluctuation from intermittent production by renewables, mainly wind in case of Finland where solar has minor role, may strain the equipment of the production capacity that must cover for the gaps created by periods of unavailable renewables. Such periods are fairly predictable in short term, but this will not protect the complementing plants from the impact of resulting cycling and ramping loads. The

risk is low as long as the gaps are covered by very flexible options like spinning reserves and hydro power, but beyond that shortened equipment life could be expected in load-following plants at components that suffer most from thermal transients.

The change from the creep-dominated service to increasing cyclic contribution will not only reduce the expected life of the high temperature components, but also grow the economic pressure to the complementing plants, such as fossil steam plants and CHP units. In countries where this process has proceeded further than in Finland, there is for example more shift from coal to gas fired plants that may respond faster in cycling service, and also emit less CO<sub>2</sub>. In Finland, significant reduction to CO<sub>2</sub> emissions is expected from new nuclear capacity that would however not help much in supply fluctuation. The challenge will therefore remain to develop the flexible production mix, as further wind power will be added. Because of the overriding needs by climate policies, attempts to consider for example new materials, higher operating pressures and temperatures, and larger efficient units of thermal power have been delegated to position of lesser urgency. It also means more importance to solutions to simultaneously maintain or possibly upgrade the availability and flexibility of the existing capacity as much as possible.

## Acknowledgements

The authors wish to acknowledge the financial support of the VTT service development program ProperScan®.

## References

1. Pertti Auerkari, Jorma Salonen, Stefan Holmström, Anssi Laukkanen, Juhani Rantala and Reino Nikkarila. Creep damage and long term life modelling of an X20 steam line component. *Engineering Failure Analysis* 35 (2013) 508-515.
2. Rami Pohja, Stefan Holmström, Pertti Auerkari and Asta Nurmela. Predicted life of P91 steel for cyclic high temperature service. *Materials at High Temperatures* 34 (2017) 301-310.
3. Wind power generation in Finland 11-17.2.2019. Fingrid, [www.fingrid.fi](http://www.fingrid.fi). Accessed 18.2.2019.
4. Tiina Koljonen, Sampo Soimakallio, Antti Lehtilä, Lassi Similä, Juha Honkatukia, Mikael Hildén, Antti Rehunen, Laura Saikku, Marja Salo, Mikko Savolahti, Pekka Tuominen, Terttu Vainio. Long-term development of total emissions. Publications of the Government's analysis, assessment and research activities 24/2019. Prime Minister's Office, February 2019 (in Finnish). 162 p.
5. National and regional status of emission-related electricity production and cross-border distribution, see [www.electricitymap.org](http://www.electricitymap.org), accessed 06-05-2019.
6. EN 12952-4: 2011. Water-tube boilers and auxiliary installations. Part 4: In-service boiler life expectancy calculations. CEN, Brussels, 1 + 21 p.
7. EN 13480-3: 2017. Metallic industrial piping. Part 3: Design and calculation. CEN, 1+ 363 p.
8. ASME Boiler and Pressure Vessel Code, Section III Div. 1 Sub-Section NH: ASME, 2007.
9. Design and Construction Rules for Mechanical Components of FBR Nuclear Islands and High Temperature Applications: RCC-MRx Design Code, AFCEN, 2012.
10. EN 13445-3:2014/A2:2016. Unfired pressure vessels. Part 3: Design, Annex M. In service monitoring of vessels operating in fatigue or creep service. CEN, 6 p.
11. Assessment procedure for the high temperature response of structures: The R5 Procedure, 2003.
12. Stuart Holdsworth. Creep-ductility of high temperature steels: A review. *Metals* 9 (2019) 342, 13 p. doi:10.3390/met9030342.

13. PD 7910. Guide to methods for assessing the acceptability of flaws in metallic structures.
14. Pertti Auerkari, Rami Pohja, Sanni Yli-Olli, Satu Tuurna, Pekka Pohjanne, Ulla McNiven. RBI and probabilistic life assessment for components of coal and co-fired power plants. 41st MPA Seminar, October 5th and 6th, 2015, Stuttgart. 11 p.
15. VGB Standard VGB-S-517-00-2014-11-DE-EN. Guidelines for rating the microstructural composition and creep rupture damage of creep-resistant steel for high pressure pipelines and boiler components and their weld connections. VGB PowerTech e.V., Essen 2014, 71 p. + app.
16. VGB-Richtlinie VGB-R 509: Wiederkehrende Prüfungen an Rohrleitungsanlagen in fossil-befeuerten Wärmekraftwerken. VGB PowerTech e.V., Essen.
17. VGB-Standard VGB-S-506-R-00;2012-03-EN. Condition Monitoring and Inspection of Components of Steam Boiler Plants, Pressure Vessel Installations and High-Pressure Water and Steam Pipes. VGB PowerTech e.V., Essen 2012.
18. EN 16991:2018. Risk-based inspection framework. CEN, Brussels. 1+86 p.
19. API RP 581. Risk-Based Inspection Methodology. American Petroleum Institute. 2016.