

VTT Technical Research Centre of Finland

Electrostatic filter construction

Kulmala, Ilpo; Heinonen, Kimmo

Published: 02/07/2014

Document Version
Publisher's final version

[Link to publication](#)

Please cite the original version:

Kulmala, I., & Heinonen, K. (2014). Electrostatic filter construction. (Patent No. *EP 1 492 622 B1*). European Patent Office (EPO). <https://worldwide.espacenet.com/patent/search?q=pn%3DEP1492622B1>



VTT
<http://www.vtt.fi>
P.O. box 1000FI-02044 VTT
Finland

By using VTT's Research Information Portal you are bound by the following Terms & Conditions.

I have read and I understand the following statement:

This document is protected by copyright and other intellectual property rights, and duplication or sale of all or part of any of this document is not permitted, except duplication for research use or educational purposes in electronic or print form. You must obtain permission for any other use. Electronic or print copies may not be offered for sale.



(11) **EP 1 492 622 B1**

(12) **EUROPEAN PATENT SPECIFICATION**

(45) Date of publication and mention of the grant of the patent:
02.07.2014 Bulletin 2014/27

(21) Application number: **03712196.9**

(22) Date of filing: **10.04.2003**

(51) Int Cl.:
B03C 3/155 (2006.01)

(86) International application number:
PCT/FI2003/000272

(87) International publication number:
WO 2003/084665 (16.10.2003 Gazette 2003/42)

(54) **ELECTROSTATIC FILTER CONSTRUCTION**
ELEKTROSTATISCHE FILTERAUSFÜHRUNG
STRUCTURE DE FILTRE ELECTRIQUE

(84) Designated Contracting States:
AT BE BG CH CY CZ DE DK EE ES FI FR GB GR HU IE IT LI LU MC NL PT RO SE SI SK TR

(30) Priority: **11.04.2002 FI 20020700**

(43) Date of publication of application:
05.01.2005 Bulletin 2005/01

(73) Proprietor: **Oy Lifa Iaq Ltd.**
00550 Helsinki (FI)

(72) Inventors:
• **KULMALA, Ilpo**
FIN-33100 Tampere (FI)

• **HEINONEN, Kimmo**
FIN-33720 Tampere (FI)

(74) Representative: **Lipsanen, Jari Seppo Einari et al**
Seppo Laine Oy
Itämerenkatu 3 B
00180 Helsinki (FI)

(56) References cited:
WO-A1-98/22222 WO-A2-02/20162
US-A- 5 403 383 US-A- 5 549 735

EP 1 492 622 B1

Note: Within nine months of the publication of the mention of the grant of the European patent in the European Patent Bulletin, any person may give notice to the European Patent Office of opposition to that patent, in accordance with the Implementing Regulations. Notice of opposition shall not be deemed to have been filed until the opposition fee has been paid. (Art. 99(1) European Patent Convention).

Description

[0001] The present invention relates to an electrostatic filter construction gas and particle filter according to the preamble of Claim 1.

[0002] Consciousness of air impurities and the health hazards caused by them has increased considerably in recent years. Research has shown that gaseous and particulate impurities are environmental exposure agents that clearly increase sickness and health hazards. The problems are worst in large cities, in which emissions from traffic and energy production pollute the air. Besides their health hazards, impurities in outdoor air also affect the corrosion and oxidation of materials.

[0003] Attempts are made to reduce the impurities travelling from outside to the indoor air of buildings and vehicles by filtering the incoming air. Nowadays, the replacement air for dwellings, offices, and commercial buildings is cleaned using only particle filters; gases are filtered mainly only in special cases (e.g., clean rooms, electrical and electronics rooms).

[0004] The separation ability of particle filters varies greatly depending of the size of the particles. Fibre filters separate particles well if they are more than 5 μm , such as, for example, pollens. However, most of the emissions from traffic and energy production are small particles (particle size less than 1 μm), which are much more difficult to filter.

[0005] One effective way to filter small particles is the electrostatic precipitator shown in Figure 1, the operation of which is based on an electrically charged particle and the force exerted by an electrical field on the particle. In conventional two-stage electrostatic precipitators used in air-conditioning applications, the airflow and the particles in it are first led through a charger section 1, in which they are charged electrically. The figure shows the corona wires 4 and the path 3 of the ions. After this, the airflow travels to a collector section 2, which is formed of alternating collector 9 and high-voltage electrodes 15, according to Figure 1. The figure shows the path of a positively charged particle 5 from the filter. The corona voltage value is typically +8 kV and the collector plate value +4 kV. The distance between the plates is typically in the order of 5 mm, so that a normally sized cell contains about 100 plates. Drawbacks with an electrostatic precipitator are the complexity of the solution and its subsequent expensiveness. At the same time, the dust collecting on the collector plates can cause spark-overs, which lead to the production of unhealthy ozone, an unpleasant sound, and a temporary weakening of the filtering efficiency.

[0006] According to Figure 2, electrostatic precipitation can also be applied to a fibre filter. The particles are charged in the same way as in the electrostatic precipitator, but the collection section 2 is formed of a fibre filter 7, above which a power electrical field is arranged with the aid of a metal mesh 7. This solution too does not eliminate the ozone production problem. The metal mesh 7 has no filtering properties.

[0007] Recently, combination filters have appeared on the market, which filter gases and particles. However, the small-particle separation efficiency of combination filters is quite modest (they generally belong to the filter class EU6 - EU7, which means, for example, that they filter a half or less of the 0,3- μm particles). The ability of the filters to charge gases is very modest in relation to the nominal airflow. US patent 5,108,470 (Charging element having odour and gas absorbing properties for an electrostatic air filter) discloses a filter, in which a flat electrode containing activated carbon is located between two filter structures. The activated-carbon electrode is connected to an electrical power circuit. The construction is surrounded by metal electrodes, which have no filtering properties. The filter construction is at right angles to the direction of flow.

[0008] Application WO 98/22222 (Device in connection with an electrostatic filter) in turn discloses placing a fibre filter between two or more activated-carbon electrodes. In this case, the direction of the flow is at right angles to the electrodes.

[0009] A general problem with flat-plate filter solutions is the small amount of gas filtering material: for the filter to be able to effectively separate gaseous impurities, the transit time through the filter material should be sufficiently long. The small amount of adsorptive material means that the charging capacity of the solutions described for gaseous impurities remains low. For this reason, the filters have a short service life. By adding consecutive filtering stages, the gas filtering ability of the alternatives referred to above can be increased, but at the same time the pressure drop will increase.

[0010] The capacity of a gas filter can be increased by using a corrugated construction, as disclosed in patent US 5,549,735 (Electrostatic fibrous filter). The patent discloses a solution, in which there is a charger section, a high-voltage electrode with the same polarity as the charger section, and an earthed activated carbon electrode. The high voltage is used to form an electrical field between the metal mesh and the activated carbon electrode. In this solution the electrodes are perpendicular to the air flow.

[0011] The metal mesh does not have filtering properties. It is difficult to make an even electrical field, because close to the tops of the corrugations the distance of the electrodes easily differs from what it is in the flat section. When making the creases, the upper and lower parts of the corrugations must be sealed. In addition, the parts must be impermeable to air, because the upper and lower parts do not participate in filtering.

[0012] To produce clean incoming air, a filter must be able to filter not only small particles, but also gaseous impurities. One problem is the pressure drop over the filter: present solutions cannot provide effective particle and gas filtering simultaneously with a low pressure drop. Effective filtering is also expensive to implement. In practice, this means that existing air-conditioning machinery would require more powerful and also noisier fans, in

order to compensate for the pressure drop caused by the additional filtering. An increasing pressure drop over the filter will require a corresponding increase in fan energy, thus correspondingly increasing the power consumption of the fans.

[0013] WO0220162 describes an electrostatic precipitator type filter is combined with replaceable, polarizable trapping media. In one aspect of the invention, the media is fitted between polarizing plates. In another aspect, the media is coated in sections to form a conductive >surface which serve as the equivalent to the charged plates of the precipitator. These electrodes may be alternately displaced to provide a ready means to effect electrical connections. US5403383 describes an electrostatically stimulated air filter and process, which contemplates a housing having a fluid intake and a fluid exhaust; an upstream electrode, disposed downstream of the fluid intake, for carrying a ground potential; a filter, disposed downstream of the prefilter, for filtering out contaminants in the fluid; an ionizing electrode, disposed between the filter and the prefilter, for carrying a second potential; and a downstream electrode, disposed downstream of the filter, for carrying a ground potential; and a fan, downstream of the filter, for driving air through the prefilter and the filter. Ionization of incoming fluid occurs as a result of electric fields generated by the downstream electrode, the ionizing electrode, and the upstream electrode. The filter comprises an upstream dielectric layer and a downstream conductive layer, usually fibers coated with activated carbon powder.

[0014] The invention is to create an entirely new type of particle filter.

[0015] The invention is based on the fact that at least one of the filter's electrodes is formed of an air-permeable, typically porous material with a poor electrical conductivity, such as activated carbon, in the form of a bag. In addition, both electrodes are positioned substantially parallel to the direction of flow of the gas.

[0016] More specifically, the particle filter according to the invention is characterized by what is stated in the characterizing portion of Claim 1.

[0017] Considerable advantages are gained with the aid of the invention.

[0018] With the aid of this invention, air (or some other gas) is cleaned effectively of both gaseous and particulate impurities. The construction also permits a solution with a low pressure drop. For this reason, the filter can be installed in existing ventilation systems, without changes being required in the fans. In addition to having low operating costs, the solution is also economical to implement.

[0019] The benefits of the solutions are:

- effective combined gas and particle filtering,
- a long service life, if used as a filter for individual rooms,
- a low pressure drop and thus low energy costs,
- control of the production of the deleterious ozone

that appears in electrostatic filters: the gas filter removes the ozone that arises in the corona discharge,

- elimination of the need for filter-cell cleaning that arises in electrostatic filters: dirtied filters are changed frequently,
- manufacture of the construction is simple and economical,
- the used replaceable component can be manufactured from materials that can be disposed of by e.g. burning,
- the fibre filter also acts as the insulating material for the electrodes,
- the carbon-fibre electrodes can be preferably manufactured, for example, by sewing, making the replaceable filter components particularly cheap to manufacture.

[0020] The changing of the filter also eliminates the typical problem of electrostatic filters, i.e. the cleaning of dirt collected on the filter cells. Collected dirt is often difficult to clean, it can corrode the collector electrodes and causes spark-over between the collector and voltage electrode. This in turn causes ozone production, weakening in the collection efficiency, and an unpleasant sound. Nowadays, unreliability is indeed one of the biggest problems relating to electrostatic filtering.

[0021] In the following, the invention is examined with the aid of examples and with reference to the accompanying drawings.

Figure 1 shows a schematic diagram of one filter solution according to the prior art.

Figure 2 shows a schematic diagram of a second filter according to the prior art.

Figure 3 shows a schematic diagram of the filter solution according to the invention.

Figure 4 shows graphically the pressure drops of a particle filter according to the invention and a commercial particle filter.

Figure 5 shows graphically the degree of separation of a filter according to the invention, as a function of the airflow.

Figure 6 shows graphically a comparison of the particle separation of the prior art and the invention.

Figure 7 shows a side view of an electrostatic filter according to the invention.

Figure 8 shows the filter according to Figure 7, seen from the direction of the air flow.

Figure 9 shows the filter according to Figure 7, seen from the direction of the air flow and without the

charging unit.

Figure 10 shows the filter according to Figure 7, seen from the rear (against the flow of air).

[0022] In the following, the invention is examined with the aid of the following terms:

- 1 charging section
- 2 separation section, electrostatic filter
- 3 ion path
- 4 corona wire
- 5 positive charge
- 6 air flow
- 7 fibre filter
- 8 metal mesh
- 9 separation plate
- 10 charging unit
- 11 high voltage
- 12 fibre filter
- 13 activated carbon filter
- 14 positive electrode of the activated carbon filter
- 15 earthed electrode of the activated carbon filter

[0023] Figure 3 shows a solution according to the invention. In the filter, electrical forces are exploited by charging the particles with the aid of a corona discharge produced, for example, using corona wires 4, and collected with the aid of an electrical field in a collector unit 2. In the charger unit 10 and the collector unit 2, voltages of the order of 8 - 10 kV can be used. With the aid of the electrical forces, effective filtering can be achieved for small particles too, without high pressure drops.

[0024] A new feature in the filter is that both electrodes 14 and 15 are manufactured from activated carbon, or some other material containing a substance that filters gases, and which has a low electrical conductivity. In this case, a material with a low electrical conductivity refers to a material with a surface resistance in the order of 10^9 - 10^{15} Ohms.

[0025] The electrodes 14 and 15 are thus typically of a porous material. One material of the electrode 14 can be, for example, a porous polymer with low electrical conductivity. Between the electrodes 14 and 15 a rough filter material (fibre filter) 12 is placed, which is economical and which has a low pressure drop. Other materials permeable to air can also be used as the filter material, provided they are sufficiently porous. The fibre filter 12 also acts as a separator between the high-voltage electrodes 14 and the earthed electrodes 15, to prevent spark-overs.

[0026] According to Figure 3, the electrode constructions 15 are preferably positioned to form bag-like pockets, through which the gas being filtered must travel. The fibre filter 12 and the electrode 14 are placed inside the bag-like electrode 15, in such a way that the electrodes 14 and 15 are more or less parallel. The maximum depth of the fibre filter 12 in the direction of flow of the air can be the same as the depth of the pocket formed by the

bag-like electrode 15.

[0027] The electrodes 14 and 15 are positioned substantially according to the direction of flow of the gas. According to the invention, this means that the angle of the electrodes 14 and 15 relative to the direction of flow is no greater than 45° . When examining the angle, the effective area of the electrodes must be taken into consideration. In the small fold areas of the electrodes 14 and 15, which account for a few percent of the flow, the angle of the electrodes may deviate from the limit value stated above.

[0028] To make the point clear, transverse filters, which do not come within the scope of the invention, are typically at an angle of 90° to the direction of flow.

[0029] In order to bring the electrical filtering effect to a sufficient level, there should be a high difference in voltage potential between the electrodes 14 and 15. This can be implemented in two ways, but in practice a simple construction is one in which the electrode 14 is connected to a high voltage and the electrode 15 is earthed according to Figure 3. This electrode can also be left floating, though this may weaken the filtering effect.

[0030] Naturally, the positions of the earthed and live electrodes in Figure 3 can be reversed, i.e. the high voltage can be connected to the electrode 15 while the electrode 14 can be earthed or left to float.

[0031] In a solution according to the invention, the component 12 containing the filter material is preferably changeable. Alternatively, the entire collector section 2 can be changeable. The interval between changes depends on the environmental conditions and the airflow. If the solution is being used for filtering the incoming air in an individual room, the changing interval can be in the order of 1000 - 3000 hours, i.e. clearly more than one order of magnitude greater than when using the present filters installed in a central air-conditioning machine. As the ventilation is typically used for only part of the day, the change interval will be in the order of 6 - 12 months. The most expensive part of the solution, i.e. the high-voltage supply and the charger 10 are, on the other hand, permanent, which reduces the filter's operating costs. An examination of the total costs of the filtering shows the costs to be low for the whole service life of the filter.

[0032] The solution compactly combines particle and gas filtering. The space required is clearly less than when using separate filters (gas filter + particle filter) of a corresponding capacity. For example, for an airflow of 50 l/s, the space required is in the order of 0,3 m x 0,3 m x 0,3 m. The external dimensions can be further reduced from even this, with no loss of effectiveness in particle filter, though this will also reduce the capacity of the gas filter (the changing interval will be shortened).

[0033] In this invention, materials with a low electrical conductivity are used as the electrodes. This will limit the increase in current in a possible short circuit, so that the filter will still operate even in fault situations in which other electrical filters no longer operate.

MEASUREMENT RESULTS

[0034] Figures 4 - 6 show the preliminary measurement results of a prototype filter made for the solution. The prototype's external dimensions are in the order of 30 cm x 30 cm x 30 cm. In the prototype, the properties of the filter have not been optimized, so that it is probable that by selecting the materials and making changes in the construction even better values can be achieved. The results show, however, that even the present level achieves powerful particle and gas filtering with a low pressure drop.

[0035] Figure 4 shows the pressure drops for the present invention and a particle filter of the same size class of a known manufacturer. The particle filter is a HEPA class, with a separation capacity of > 95 % for 0,3- μm particles, i.e. its filtering capacity is in the same class as that of the invention. The figure shows that even the particle filter by itself has a greater pressure drop than the present invention.

[0036] Figure 5 shows the effectiveness of the prototype filter in filtering a test gas (toluene, generally used as a test gas). The figure shows that as the airflow increases, the permeability increases (the separation efficiency diminishes), but that for an airflow of 50 Us it is still in the order of 95 %. This is the same order as the gas separation efficiencies of the combined gas and particle filters of commercial manufacturers.

[0037] Figure 6 compares the separating capacity of the present invention with that of commercial products. Without electrical forces ($U = 0$ kV), the separation efficiency is extremely modest, but with the aid of particle charging and of an electrical field the separation efficiency increases enormously. The commercial filters have a relatively modest separation efficiency for small particles, whereas a filter equipped with activated-carbon bags will separate more than 95 % of 0,3- μm particles, when the airflow is in the order of 50 l/s. It is precisely these small particles that are most hazardous to human health, because they can travel as far as the innermost parts of the lungs.

[0038] Figures 7 - 10 show photographs of the construction shown in Figure 3. The figures shows the bag-likeness of the activated carbon electrodes 15 and the modular construction, which allows the transverse size of the filter to be easily altered by adding more 'bag elements'.

[0039] According to the invention, one of the electrodes can be made from an electrically conductive material. In this case, the bag-like electrode can be of a material with a low electrical conductivity.

SUMMARY

[0040] With the aid of the present invention, it is possible to filter out the small particles that are most hazardous to human health effectively and economically. In addition, the gas filtering makes it possible to eliminate gas-

es that are hazardous to health, as well as unpleasant odours. By selecting suitable material and impregnation substances the solution can also be used to protect products and devices from corrosion and oxidation.

[0041] Thanks to its performance values and simple construction, the solution has a wide range of applications in cleaning air and other gases.

10 Claims

1. A combined gas and electrostatic filter construction (2), which includes

- 15 - first electrodes (14),
- second electrodes (15), which are electrically insulated from the first electrodes (14), and
- an insulating material (12) acting as a particle filter, which is located between the first (14) and the second electrodes (15), whereby
- 20 - a difference in electrical potential between the electrodes (14, 15) can be created, in order to create an electrical field between the electrodes (14, 15),
- 25 - the material (14, 15) of at least one of the electrodes (14, 15) is a material, such as activated carbon, which is permeable to air and which filters gases, and which has a low electrical conductivity with a surface resistance in the order of 10^9 - 10^{15} Ohms, and
- 30 - the gas filtering electrode (15) is shaped to form a bag,

characterized in that

- 35 - both electrodes (14, 15) are set substantially parallel to the direction of the airflow such that the angle of the electrodes (14) and (15) relative to the direction of flow is not greater than 45° .
2. An electrostatic filter construction (2) according to Claim 1, **characterized in that** one electrode (15) with low electrical conductivity is constructed like a bag and particle filtering is arranged inside it with the aid of the filter material (12) and the electrodes (14, 15).
3. An electrostatic filter construction (2) according to Claim 1 or 2, **characterized in that** one of the electrodes (14, 15) has low electrical conductivity with a surface resistance in the order of 10^9 - 10^{15} Ohms and the other is electrically conductive.
4. An electrostatic filter construction (2) according to any of the above Claims, **characterized in that** one of the electrodes (14, 15) is connected to an earth potential and the other to a higher potential.

5. An electrostatic filter construction (2) according to any of the above Claims, **characterized in that** one of the electrodes (14, 15) is allowed to float and the other is connected to an earth potential.
6. An electrostatic filter construction (2) according to any of the above Claims, **characterized in that** the electrodes (14, 15) are arranged in such a way that at least most of the airflow is arranged to travel through the bag-like electrode (15).
7. An electrostatic filter construction (2) according to any of the above Claims, **characterized in that** a charging section (1), which charges the particles to be filtered, is arranged before the filter (2) in the path of the air flow.
8. An electrostatic filter construction (2) according to any of the above Claims, **characterized in that** the filter material (12) is arranged to be changeable.

Patentansprüche

1. Kombiniertes Gas- und Elektrostatik-Filteraufbau (2), enthaltend:
 - erste Elektroden (14),
 - zweite Elektroden (15), die elektrisch von der ersten Elektrode (14) isoliert sind, und
 - einen als Partikelfilter fungierenden Isolierstoff (12), der sich zwischen den ersten (14) und den zweiten Elektroden (15) befindet, wobei
 - eine Differenz des elektrischen Potentials zwischen den Elektroden (14, 15) erzeugbar ist, um ein elektrisches Feld zwischen den Elektroden (14, 15) zu erzeugen,
 - das Material (14, 15) mindestens einer der Elektroden (14, 15) ein Material wie zum Beispiel Aktivkohle ist, das luftdurchlässig ist und Gase filtert, und das eine geringe elektrische Leitfähigkeit bei einem Flächenwiderstand von $10^9 - 10^{15}$ Ohm besitzt, und
 - die Gasfilterelektrode (15) in Form eines Beutels geformt ist,

dadurch gekennzeichnet, dass

 - beide Elektroden (14, 15) im wesentlichen parallel zu der Richtung des Luftstroms eingestellt sind, so dass der Winkel der Elektroden (14) und (15) relativ zu der Strömungsrichtung nicht größer als 45° ist.
2. Elektrostatik-Filteraufbau (2) nach Anspruch 1, **dadurch gekennzeichnet, dass** eine Elektrode (15) mit geringer elektrischer Leitfähigkeit ähnlich wie ein Beutel aufgebaut ist und in diesem eine Partikelfilterung mit Hilfe des Filtermaterials (12) und der Elektroden (14, 15) ausgebildet ist.

3. Elektrostatik-Filteraufbau (2) nach Anspruch 1 oder 2, **dadurch gekennzeichnet, dass** eine der Elektroden (14, 15) geringe elektrische Leitfähigkeit bei einem Flächenwiderstand in der Größenordnung von $10^9 - 10^{15}$ Ohm aufweist, und die andere Elektrode elektrisch leitend ist.
4. Elektrostatik-Filteraufbau (2) nach einem der obigen Ansprüche, **dadurch gekennzeichnet, dass** eine der Elektroden (14, 15) mit Erdpotential verbunden ist, die andere mit einem höheren Potential.
5. Elektrostatik-Filteraufbau (2) nach einem der obigen Ansprüche, **dadurch gekennzeichnet, dass** eine der Elektroden (14, 15) potenzialfrei bleiben kann, während die andere Elektrode mit Erdpotential verbunden ist.
6. Elektrostatik-Filteraufbau (2) nach einem der obigen Ansprüche, **dadurch gekennzeichnet, dass** die Elektroden (14, 15) in der Weise angeordnet sind, dass mindestens der größte Teil des Luftstroms so verläuft, dass er durch die beutelähnliche Elektrode (15) läuft.

7. Elektrostatik-Filteraufbau (2) nach einem der obigen Ansprüche, **dadurch gekennzeichnet, dass** ein Ladeteil (1), der die zu filternden Partikel auflädt, vor dem Filter (2) im Weg des Luftstroms angeordnet ist.
8. Elektrostatik-Filteraufbau (2) nach einem der obigen Ansprüche, **dadurch gekennzeichnet, dass** das Filtermaterial (12) austauschbar angeordnet ist.

Revendications

1. Construction combinée de filtre à gaz et électrostatique (2), qui comprend
 - des premières électrodes (14),
 - des secondes électrodes (15), qui sont électriquement isolées des premières électrodes (14), et
 - un matériau isolant (12) servant de filtre à particules, qui est situé entre les premières (14) et les secondes (15) électrodes, moyennant quoi
 - une différence de potentiel électrique entre les électrodes (14, 15) peut être créée, afin de créer un champ électrique entre les électrodes (14, 15),
 - le matériau (14, 15) d'au moins une des électrodes (14, 15) est un matériau, tel que du charbon actif, qui est perméable à l'air et qui filtre des gaz, et qui possède une faible conductivité électrique avec une résistivité en surface de l'ordre de $10^9 - 10^{15}$ Ohms, et
 - l'électrode de filtration de gaz (15) est mise en

forme pour former un sac,

caractérisée en ce que

- les deux électrodes (14, 15) sont placées de façon sensiblement parallèle à la direction de l'écoulement d'air de sorte que l'angle des électrodes (14) et (15) par rapport à la direction d'écoulement ne soit pas supérieur à 45°.

2. Construction de filtre électrostatique (2) selon la revendication 1, **caractérisée en ce qu'**une électrode (15) avec une faible conductivité électrique est construite comme un sac et une filtration de particules est agencée à l'intérieur de celle-ci à l'aide du matériau de filtre (12) et des électrodes (14, 15).
3. Construction de filtre électrostatique (2) selon la revendication 1 ou 2, **caractérisée en ce qu'**une des électrodes (14, 15) possède une faible conductivité électrique avec une résistivité en surface de l'ordre de $10^9 - 10^{15}$ Ohms et l'autre est électriquement conductrice.
4. Construction de filtre électrostatique (2) selon une quelconque des revendications précédentes, **caractérisée en ce qu'**une des électrodes (14, 15) est connectée à un potentiel de masse et l'autre à un potentiel plus élevé.
5. Construction de filtre électrostatique (2) selon une quelconque des revendications précédentes, **caractérisée en ce qu'**une des électrodes (14, 15) peut flotter et l'autre est connectée à un potentiel de masse.
6. Construction de filtre électrostatique (2) selon une quelconque des revendications précédentes, **caractérisée en ce que** les électrodes (14, 15) sont agencées de manière telle qu'au moins la majeure partie de l'écoulement d'air soit agencée pour se déplacer à travers l'électrode en forme de sac (15).
7. Construction de filtre électrostatique (2) selon une quelconque des revendications précédentes, **caractérisée en ce qu'**une section de charge (1), qui charge les particules destinées à être filtrées, est agencée avant le filtre (2) dans le trajet de l'écoulement d'air.
8. Construction de filtre électrostatique (2) selon une quelconque des revendications précédentes, **caractérisée en ce que** le matériau de filtre (12) est agencé pour être changeable.

55

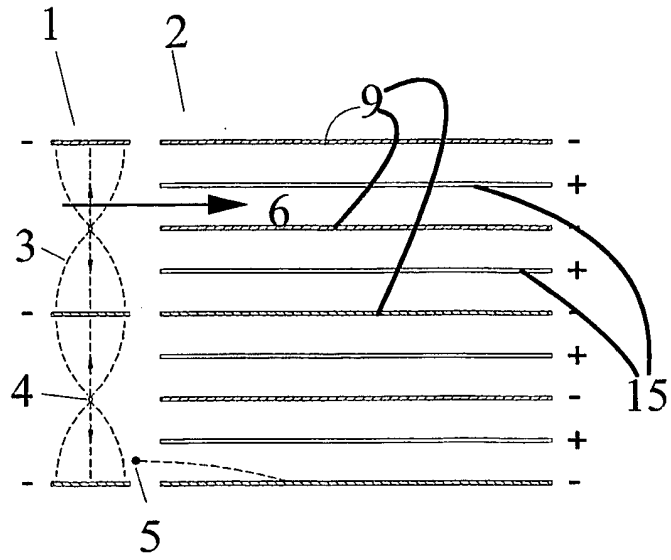

Fig. 1

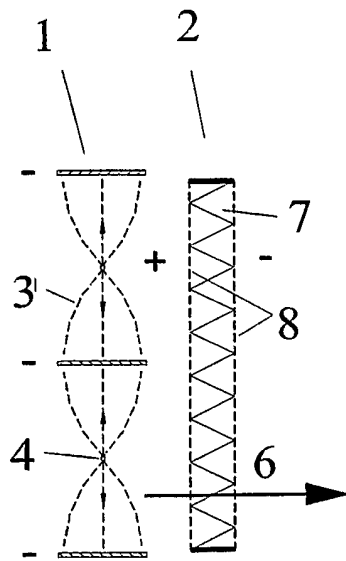

Fig. 2

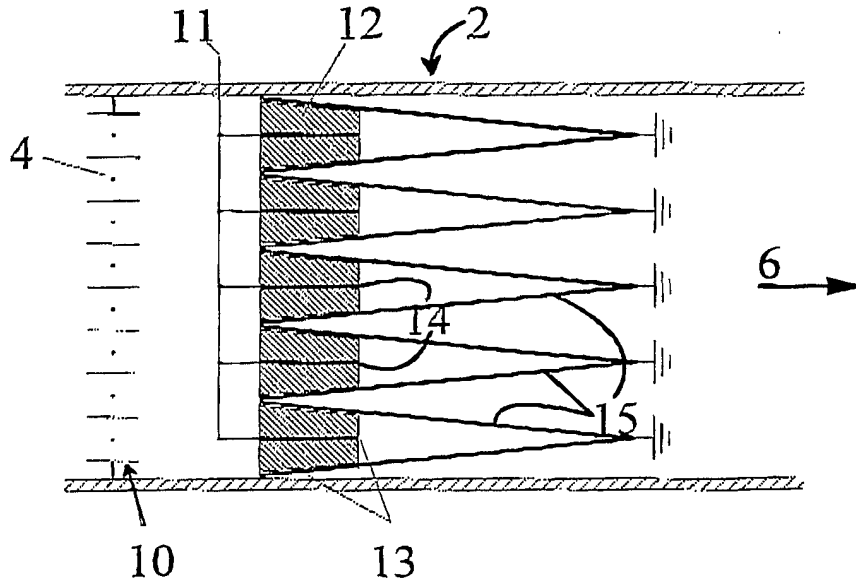

Fig. 3

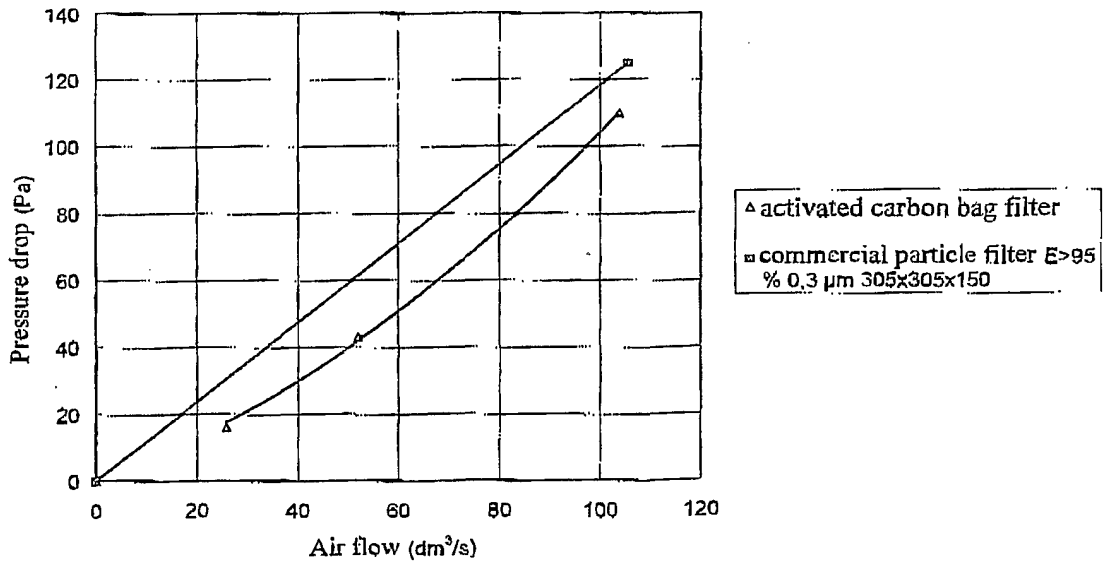

Fig. 4

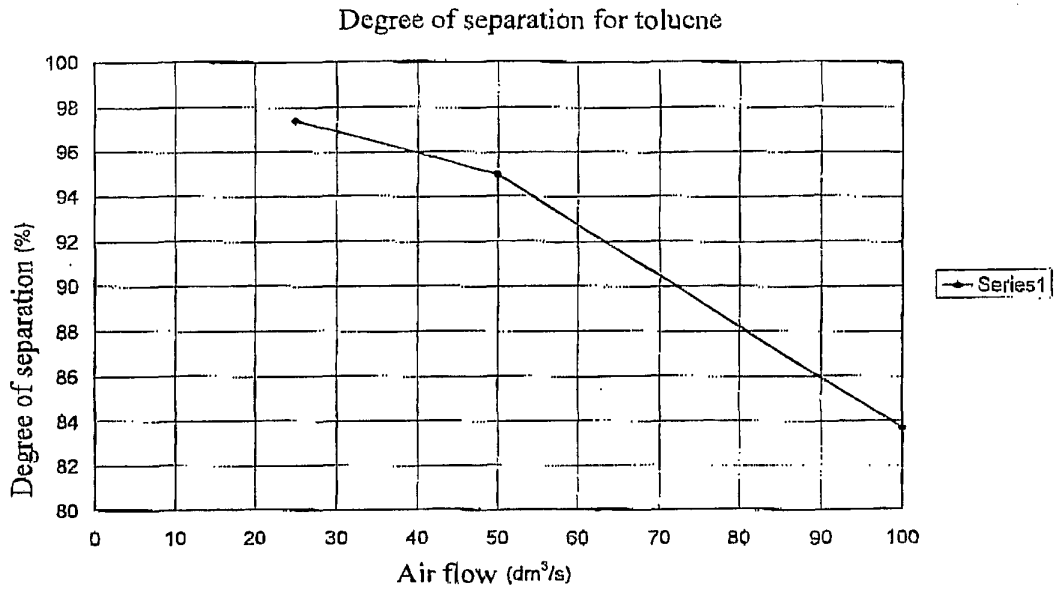

Fig. 5

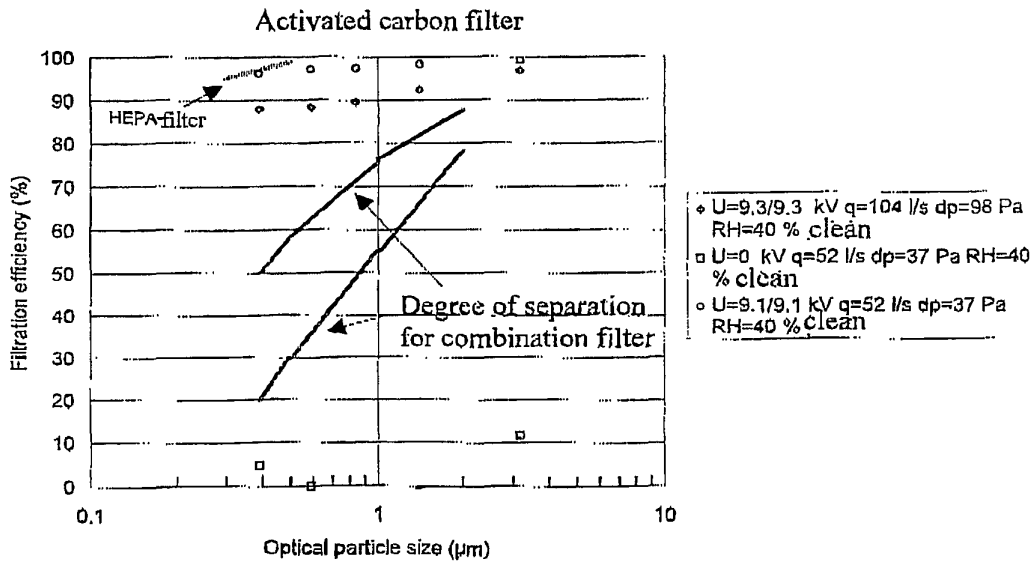

Fig. 6

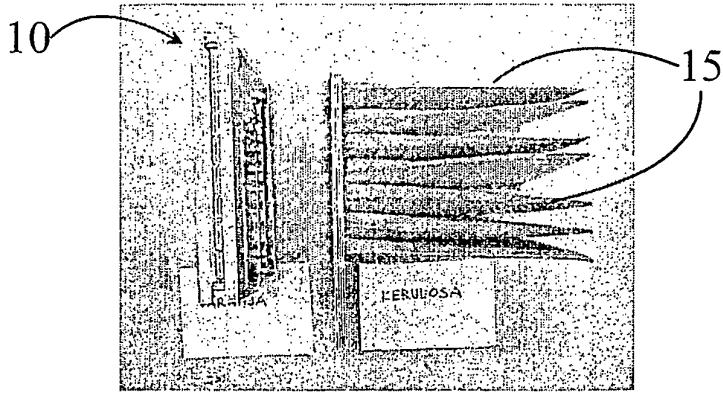

Fig. 7

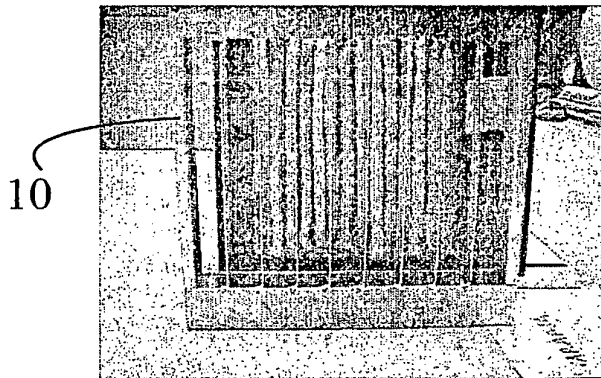

Fig. 8

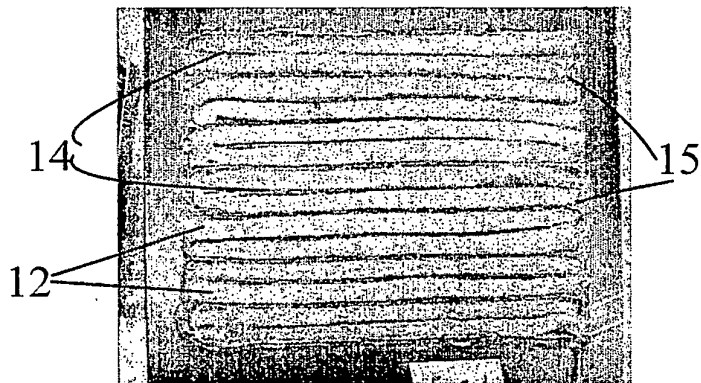

Fig. 9

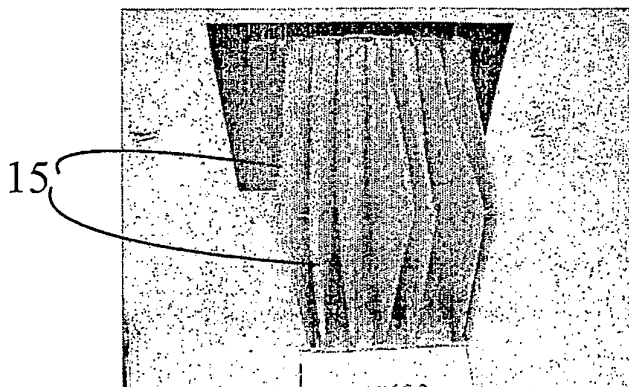

Fig. 10

REFERENCES CITED IN THE DESCRIPTION

This list of references cited by the applicant is for the reader's convenience only. It does not form part of the European patent document. Even though great care has been taken in compiling the references, errors or omissions cannot be excluded and the EPO disclaims all liability in this regard.

Patent documents cited in the description

- US 5108470 A [0007]
- WO 9822222 A [0008]
- US 5549735 A [0010]
- WO 0220162 A [0013]
- US 5403383 A [0013]