



## VTT Technical Research Centre of Finland

### Progress in decommissioning planning and licensing for VTT's FiR 1 TRIGA reactor

Airila, Markus; Kaisanlahti, Matti; Oinonen, Ville; Rätty, Antti

*Published in:*  
European Research Reactor Conference RRFM 2021

Published: 27/09/2021

*Document Version*  
Publisher's final version

[Link to publication](#)

*Please cite the original version:*  
Airila, M., Kaisanlahti, M., Oinonen, V., & Rätty, A. (2021). Progress in decommissioning planning and licensing for VTT's FiR 1 TRIGA reactor. In *European Research Reactor Conference RRFM 2021: Conference Proceedings* European Nuclear Society (ENS).

VTT  
<https://www.vttresearch.com>

VTT Technical Research Centre of Finland Ltd  
P.O. box 1000  
FI-02044 VTT  
Finland

By using VTT Research Information Portal you are bound by the following Terms & Conditions.

I have read and I understand the following statement:

This document is protected by copyright and other intellectual property rights, and duplication or sale of all or part of any of this document is not permitted, except duplication for research use or educational purposes in electronic or print form. You must obtain permission for any other use. Electronic or print copies may not be offered for sale.

# PROGRESS IN DECOMMISSIONING PLANNING AND LICENSING FOR VTT'S FIR 1 TRIGA REACTOR

M.I. Airila<sup>1\*</sup>, M. Kaisanlahti<sup>2</sup>, V. Oinonen<sup>2</sup>, A. Rätty<sup>1</sup>

<sup>1</sup>VTT Technical Research Centre of Finland Ltd, PO Box 1000, 02044 VTT, Finland

<sup>2</sup>Fortum Power and Heat Oy, PO Box 100, 00048 FORTUM, Finland

\*Corresponding Author, E-mail: [markus.airila@vtt.fi](mailto:markus.airila@vtt.fi)

## ABSTRACT

FiR 1 TRIGA Mark II research reactor, which was operated in Espoo, Finland, in 1962–2015 is nearing decommissioning. The Government of Finland granted to VTT Technical Research Centre of Finland Ltd (VTT) the decommissioning licence in June 2021, and decommissioning is scheduled to commence late 2022. Essential for the FiR 1 decommissioning project, and for fulfilling the prerequisites for the decommissioning licence, is the comprehensive contract on decommissioning services, signed in March 2020 between VTT and Fortum Power and Heat Ltd. The contract covers the dismantling of FiR 1 and all necessary nuclear waste management services as well as the radioactive waste management for OK3 laboratory decommissioning, adjacent to FiR 1. In this paper, we give an overview of the project status, including spent fuel transport for re-use in the US late 2020 (see also [1]) and present examples of progress of characterization work, detailed plans for dismantling and nuclear waste management.

## 1. Introduction

This paper presents an update of the decommissioning project of the FiR 1 TRIGA Mk II reactor, operated in Espoo, Finland, in 1962–2015 by VTT Technical research Centre of Finland Ltd. We focus on the remaining project phases (detailed planning, decommissioning and LILW management), which VTT will carry out in close collaboration with Fortum Power and Heat Ltd. Other aspect of the project have been reported in [1-6].

VTT, as the operator of FiR 1, applied from the Government of Finland for a licence for decommissioning of the reactor, and obtained the licence in June 2021. While VTT as the licensee continues to be ultimately responsible for the nuclear and radiation safety of the reactor and the decommissioning site, Fortum as the main contractor will take significant responsibility on implementing the decommissioning. The contract of VTT and Fortum, signed in March 2020, encompasses the planning of decommissioning, dismantling of the reactor, and the transfer of the waste management obligation from VTT to Fortum when the dismantling waste has been transported to Loviisa NPP for final disposal.

## 2. Project main phases and sequences

Now that the preliminary planning phase and licensing have been completed, and the SNF removed from the site, the remaining main phases of the project are detailed planning, decommissioning, LILW management and free release of the site. The planned schedule is presented in Figure 1.

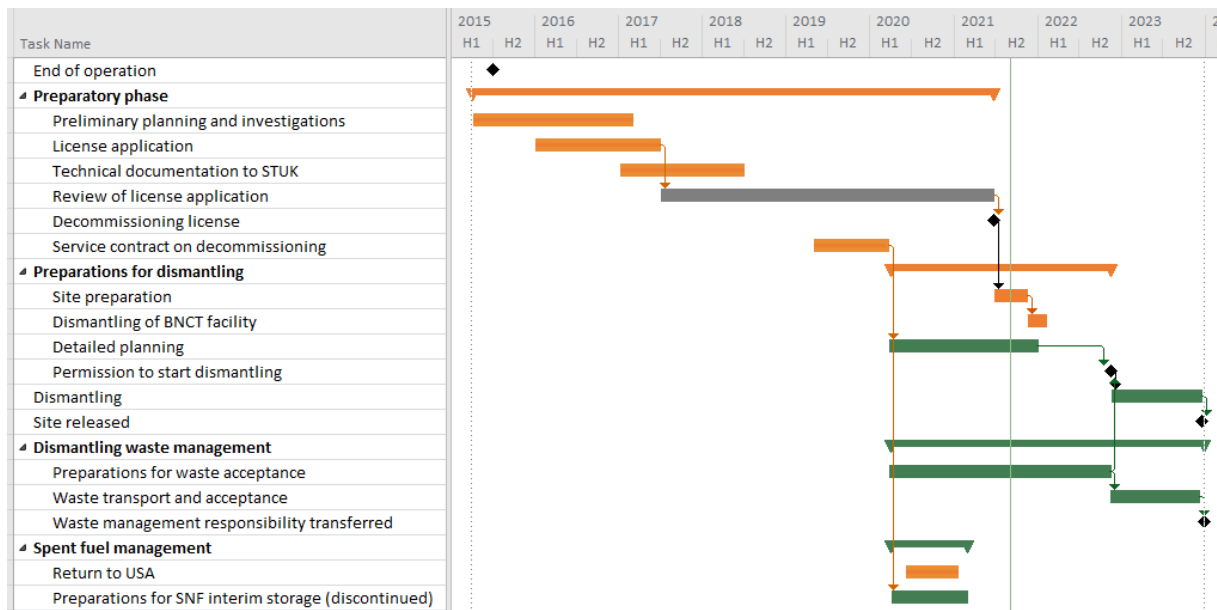

Figure 1. Schedule for FiR 1 decommissioning after shipping of the spent fuel and terminating interim storage preparations for the fuel as obsolete. Green bars represent tasks that are mostly covered by the VTT/Fortum service contract for decommissioning.

### 3. Shipping of FiR 1 spent fuel for re-use in the United States

In January 2021, the U.S. Geological Survey (USGS) in Denver, Colorado, received all the irradiated fuel from FiR 1. The USGS will use the fuel in its own reactor of the same type. The fuel, originally purchased by Finland in the 1960s and 1970s, has a remarkable remaining utility value after the permanent shutdown of FiR 1. The USGS needed additional fuel to continue operating its reactor, but the production of suitable fuel available on the market has been suspended for several years and thus it was of mutual benefit for both parties. At the end of operation, the United States will take care of the fuel.

The contract for the supply of used fuel was concluded in November 2020, and VTT arranged for the safe international transport of the fuel from Espoo, Finland to the USGS with support from Edlow International Company. The transport of fuel by road and sea was supervised by the Finnish Radiation and Nuclear Safety Authority (STUK) and USA regulatory and safety authorities.

Arranging for cooperative international spent fuel management abroad is an exception permitted by the Nuclear Energy Act. Before sending the fuel abroad, Finland received a report from the USA authorities on their commitment to the management of the fuel batch. When the USGS ceases to use its reactor, it will deliver the spent fuel to Idaho National Laboratory, where several countries have previously sent similar batches of nuclear fuel from research reactors for final handling and disposal.

### 4. Experiences from the licensing phase

In 2017–20, VTT continued planning and contracting of the waste management services after the submission of the decommissioning licence application. It is obvious now that having binding contracts for waste management in place already at the moment of the shutdown decision would have simplified planning and licensing for decommissioning, saving time and expenses. In Finland, operators are currently obliged to arrange their own waste management. This approach ensures reliable management of the bulk of nuclear waste, originating from NPP's, but it might leave out of consideration the minor waste streams from research institutes (like VTT), universities, hospitals, and industry. These learnings have been taken seriously,

and recently, a task force led by The Ministry of Economic Affairs and Employment has elaborated recommendations for further development of the national radioactive waste management [7], which has led to improvements for instance in the license conditions of the NPP facilities, allowing more flexible acceptance of waste streams from other operators.

Another related licensing process is the renewal of the license of Loviisa NPP, which will receive dismantling waste from FiR 1. This is discussed in Section 7.

### 5. Progress of characterization work

Radiological characterization data forms the basis for planning of dismantling and work instructions, waste packaging, radiation protection, site planning, transports and final disposal. Two main factors that distinguish research reactor decommissioning from power reactor decommissioning (regarding activity characterization and waste management) are various materials typically not used in power reactors (e.g. aluminium, graphite etc.) and the operating history typically containing different applications and modifications to the reactor structures. The latter one is especially important in the activity calculation model (Figure 2), where different reactor structure configurations have to be handled as separate time periods [8].

Figure 3 illustrates the progress of characterization process throughout a decommissioning project phases. VTT’s approach is to plan the dismantling method and radiation safety procedures using the preliminary calculated activities, but eventually waste management and waste final disposal will be based on nuclide vectors and the scaling matrix approach.

Characterization has focused on validating and refining the calculated results by collecting samples from different materials. An important limiting factor has been that since the spent fuel was still in the reactor core in 2015–2020, samples could be drilled only from the low active outer areas of the reactor, to avoid damaging the tank or core structures.

VTT-Fortum contract in 2020 has enabled setting Loviisa NPP waste acceptance criteria as boundary conditions to waste management planning. Therefore, forming the validated nuclide vector has been set to follow ISO 21238:2007 standard [9] as in Loviisa LILW repository, and special challenges related to especially waste final disposal can be discussed directly with the final repository facility owner. Nevertheless, since some of the material are still inaccessible before dismantling commences, the approach has been that VTT will form preliminary calculated nuclide vectors with conservative assumptions and these will be further refined and validated by Fortum during dismantling still keeping the same material-wise distribution.

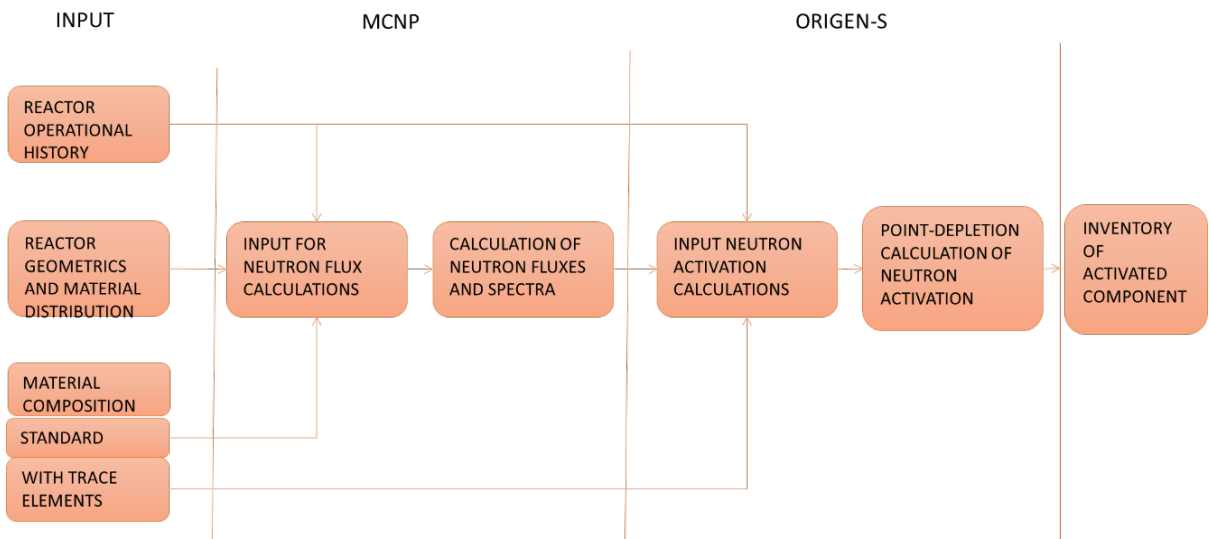

Figure 2: Activation calculation scheme.

By the end of 2021, detailed planning, integrating all site arrangements, controlled zone boundaries, logistics and security, is expected to be finalized. The plans form the basis for the final decommissioning plan and the FSAR for decommissioning, which will be prepared and submitted for regulatory approval early 2022.

Altogether VTT will need 15 nuclide vectors. Their experimental validation has required a considerable amount of effort in radiochemical method development [10-14]. However, some vectors are for very low active materials that can plausibly be cleared from regulator control. In those cases the amount of difficult-to-measure (DTM, or hard-to-measure) nuclides in the vector cannot be validated by sampling. Therefore, the characterization is performed by measuring the material composition from samples, performing the activity calculations using the measured composition and finally forming the nuclide vector by gamma spectrometric measurements using calculated scaling factors. Along with validating the nuclide vectors, characterization work in recent years has also included applying the results in refining radiation safety planning, dismantling methods and waste final disposal safety assessment. For instance, amount of activated concrete around the horizontal beam tubes can be optimized based on sample measurement from activated parts of the concrete (Figure 4) [15] and waste packages planning has been finalized taking into account the requirement from radiation shielding, logistic and waste final disposal repository.

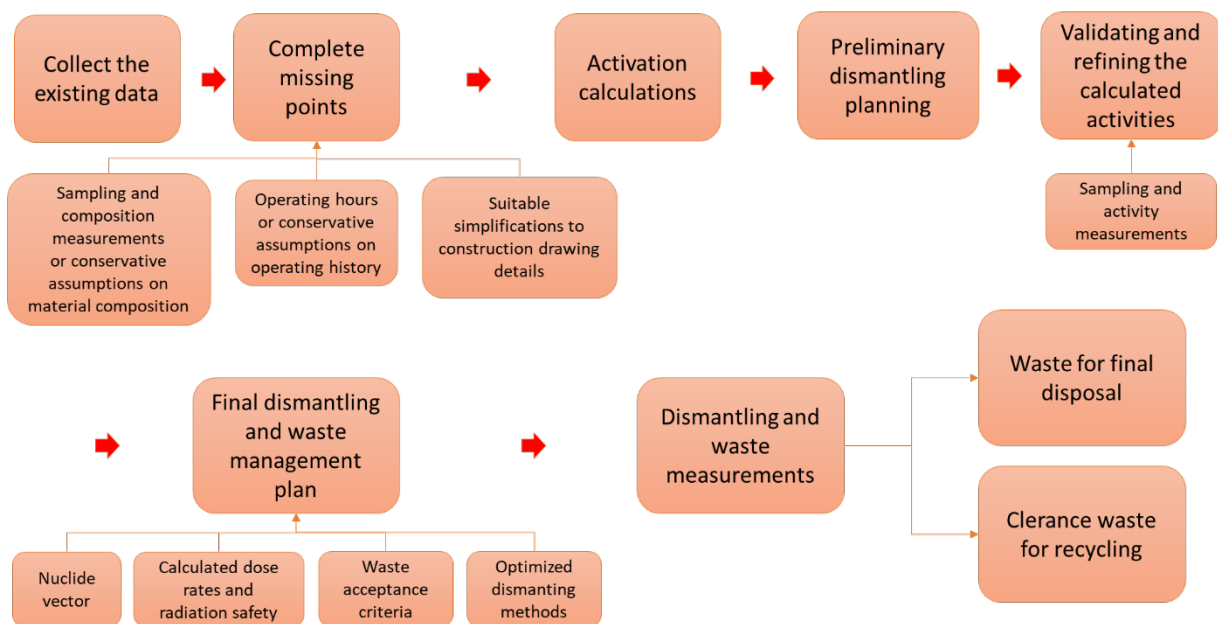

Figure 3: Progress of characterization throughout the project phases.

## 6. Plans for dismantling have evolved gradually

During operations, VTT maintained a generic decommissioning plan, which discusses possible dismantling methods and available waste management options as well as gives rough estimates for the cost and duration of decommissioning and for doses to the workers.

In 2007, VTT contracted the Finnish company Platom for a consultation on potential decommissioning strategies, including various options to execute the project, and a review of VTT's decommissioning plan for FiR 1. This work yielded suggestions for developing the plan, in particular by using experiences from Frankfurt TRIGA decommissioning in Germany. Later, in 2013, Platom reviewed available dismantling and demolition techniques and gathers systematically experiences and data from several decommissioned foreign research reactors (German HD-2, Danish DR-2 and Korean KRR-1). This work constituted one of the background

reports for FiR 1 Environmental Impact Assessment. In 2016, VTT contracted Babcock Noell GmbH to carry out detailed dismantling planning, using all specific background information from FiR 1. The resulting technical reports and work instructions constitute a significant part of the topical reports submitted to the Finnish Radiation and Nuclear Safety Authority (STUK) as part of the decommissioning licensing process.

Fortum is currently refining the detailed dismantling plan in order to include all practical considerations related to site logistics, taking waste acceptance criteria fully into account, and integrating the dismantling, waste management, radiation protection and security operations at the site. As a prerequisite for starting the dismantling, STUK requires that the final planning documentation has been delivered for review 6 months earlier and approved by STUK.

Several modern tools has been utilized for planning the decommissioning. A virtual model (eSiteview) of the plant has been created to support remote planning. Radiation modelling (MCNP and HVRC VRdose<sup>®</sup>) has been used to optimize the work process. We demonstrate with representative examples the planning sequence from inventory estimation up to final disposal. For instance, radiological characterization of the biological shield enables optimizing the amount of radwaste, the accuracy improving gradually along with the progress in sampling the concrete.

Site planning is under finalization at the moment. Site includes whole reactor building and areas outside around the building. Outside areas are fenced and gates and rotations are installed to control material flows and personnel. Site plan also describes detail layout about the site including radiation protection and waste management measures.

Radiation protection planning covers all needed radiation protection measures during the dismantling phase. Planning starts with MCNP models about reactor internals and calculating dose rates in different work phases. Based on calculated dose rates are radiation shielding and storage areas decided. All radiation protection measures and equipment's are determined and tasks are instructed in radiation protection instructions.

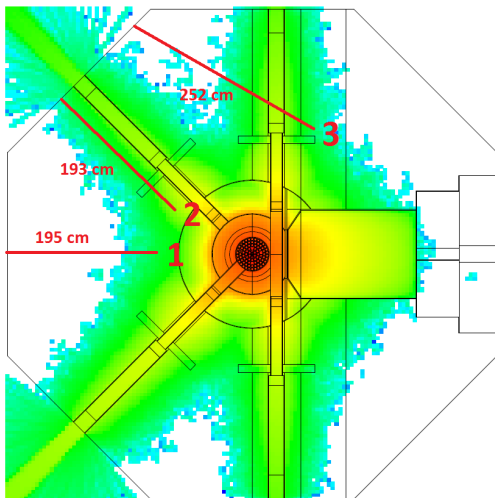

Figure 4: Left: Drilling directions towards the activated parts of the FiR 1 biological shield concrete (red lines 1, 2 and 3). Right: Drilling the specimens from the biological shield.





Figure 5. Screenshot from eSite view. Picture is from reactor platform and reactor is beneath of grid plates.

Work instructions has been done earlier in 2019. During the planning phase 2021 instructions are updated and made more detail. Dismantling equipment like cutters and grippers are determined during the process. Radiation protection measures are added as a work phase to ensure that all needed protective actions are done in correct order. Whole dismantling has been divided in 7 different dismantling phase from preparation phase to free release phase.

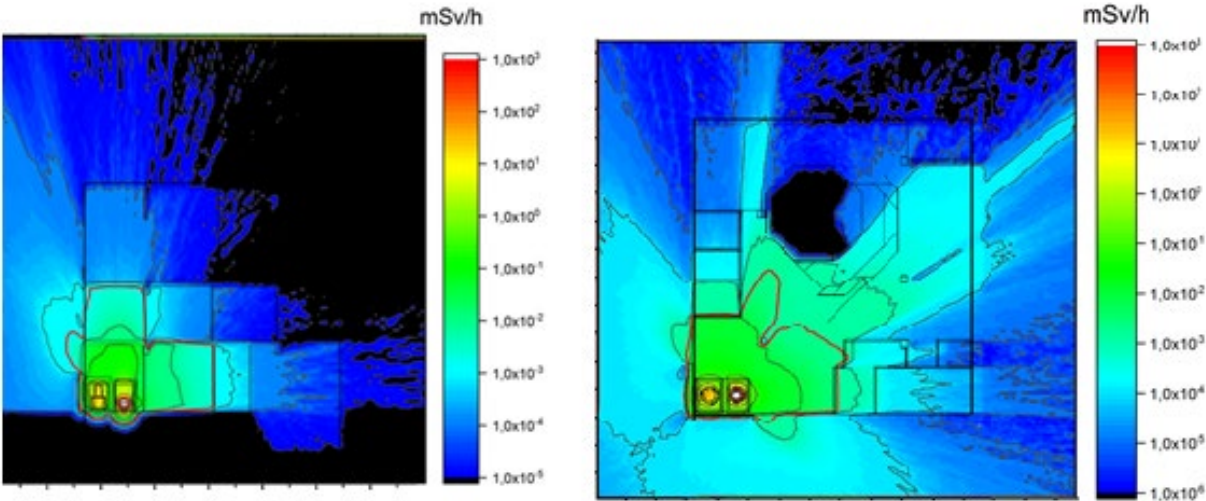

Figure 6. MCNP results. Model is made for situation where all active core parts are packed to radiation protection cylinders and final disposal packages and positioned to interim storage area. Storage area is shielded from outside with heavy concrete bars. Concrete bars are from earlier dismantled BNCT station.

## 7. Nuclear waste management

Nuclear waste management needs to be licensed and Fortum included the waste from research reactor to the licence process of potential lifetime extension of Loviisa NPP. Fortum submitted the EIA (environmental impact assessment) program in August 2020 and has been since preparing the licensing material [16].

Nuclear waste management in FiR 1 decommissioning consists packing planning, final disposal planning (safety case) and plans for free release.

A packaging plan has been made for all reactor internals in component level detail and all other waste is sorted by waste category, activity level, material and nuclide vector. Volumes and masses in each category has been evaluated resulting estimation of needed packing units. 200 l barrel is used as a standard packing unit. Besides of barrel, bigger waste container is planned for big components and concrete blocks for more efficient transportation and final disposal. Most active reactor internals are packed also inside of radiation shielding to reduce dose rate during the lifts, packing, storage, characterization, transportation and final disposal.

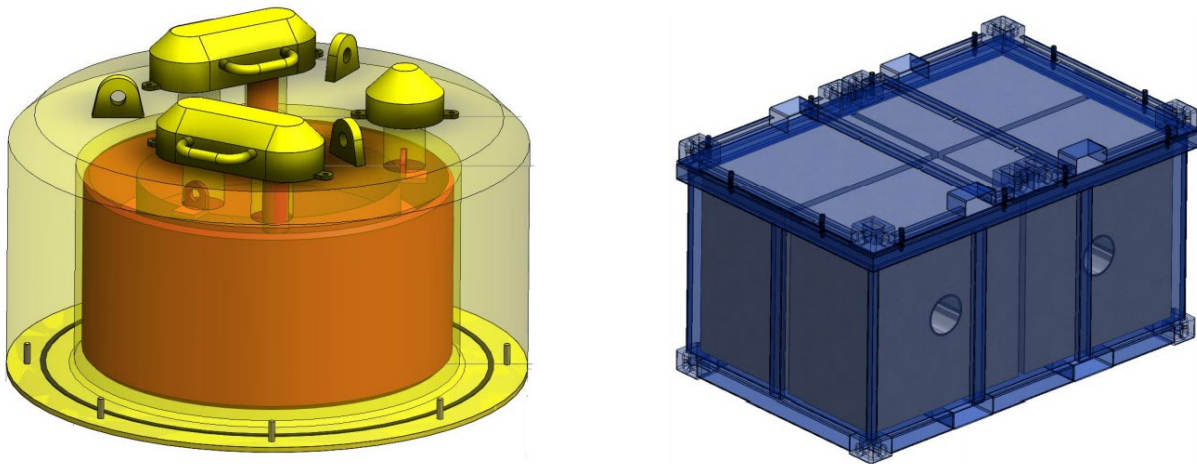

*Figure 7. Left: Radiation shield for irradiation ring. Right: Waste container for big components and concrete blocks.*

Waste categories follow Loviisa power plant's categorization principles as like other waste attributes. All necessary information about waste is collected at site and stored in power plants waste inventory database after final disposal.

Free release methods for dismantling waste are determined based on national YVL-guidelines and requirements.

Final disposal planning is done to point where logistics, waste caverns and needed equipment are determined. Next task will be finalize safety case for FiR 1 decommissioning waste. Different materials with different nuclide vectors and properties are considered. Safety case will be based on calculated activity inventory and will be fulfilled afterwards if measured values differ from calculated values. Preliminary safety case models are done already during the packing planning to ensure efficient package design.



## References

- [1] I. Auterinen, M.I. Airila, A. Rätty, T. Kekki and I.-V. Lehtinen, these proceedings.
- [2] M. Airila, I. Auterinen, P. Kotiluoto, T. Vanttola and O. Vilkkamo, The glow of Finland's first reactor fades, Nuclear Engineering International 60 (737), December 2015.
- [3] A. Rätty, M. Airila, P. Kotiluoto, O. Vilkkamo, T. Kekki, I. Auterinen, K. Calonius and P. Juutilainen, FiR1 TRIGA research reactor decommissioning project, Proceedings of the Workshop on Current and Emerging methods for Optimising Safety and Efficiency in Nuclear Decommissioning, OECD NEA, 7-9 February 2017.
- [4] M. Airila, I. Auterinen, P. Kotiluoto and A. Rätty, Lessons learned during planning and first phases of decommissioning of the Finnish Triga FIR 1, RRFM2019 - European Research Reactor Conference - Dead Sea Resort, Jordan, 24-28 March 2019.
- [5] M. Airila, Giving Birth to the First Decommissioning Licence in Finland: Case FiR 1 TRIGA reactor at VTT, RRFM 2020 - European Research Reactor Conference - Online event, 11-15 October 2020.
- [6] M. Airila, I. Auterinen, T. Kekki, P. Kotiluoto, A. Leskinen, A. Rätty, J. Siivinen and P. Viitanen, First decommissioning experiences in Finland. VTT's FiR 1 TRIGA reactor and OK3 radioactive materials research laboratory, DEM 2021 – International Conference on Decommissioning Challenges: Industrial Reality, Lessons learned and Prospects, Avignon, France, 13-15 September – 2021.
- [7] MEAE (2019) Kansallisen ydinjätehuollon yhteistyöryhmän loppuraportti, MEAE publications 2019:39  
[https://julkaisut.valtioneuvosto.fi/bitstream/handle/10024/161762/TEM\\_39\\_2019\\_KansallisenYdinjatehuollon.pdf](https://julkaisut.valtioneuvosto.fi/bitstream/handle/10024/161762/TEM_39_2019_KansallisenYdinjatehuollon.pdf)
- [8] Rätty A (2020) Activity characterisation studies in FiR1 TRIGA research reactor decommissioning project, Doctoral school in natural sciences dissertation series, University of Helsinki, URN:ISSN:2670-2010
- [9] International Organization for Standardization, Scaling factor method to determine the radioactivity of low- and intermediate-level radioactive waste packages generated at nuclear power plants, ISO 21238:2007, 2007
- [10] Leskinen A, Salminen-Paatero S (submitted March 2021) Development of  $^3\text{H}$ ,  $^{14}\text{C}$ ,  $^{41}\text{Ca}$ ,  $^{55}\text{Fe}$ ,  $^{63}\text{Ni}$  radiochemical analysis methods in activated concrete samples. J Radioanal Nucl Chem
- [11] Rätty A, Lavonen T, Leskinen A, Likonen J, Postolache C, Fugaru V, Bubueanu G, Lungu C, Bucsa A (2019) Characterization measurements of Fluental and graphite in FiR1 TRIGA research reactor decommissioning waste. Nucl Eng Des, 353:110198
- [12] Leskinen A, Salminen-Paatero S, Rätty A, Tanhua-Tyrkkö M, Iso-Markku T, Puukko E (2020) Determination of  $^{14}\text{C}$ ,  $^{55}\text{Fe}$ ,  $^{63}\text{Ni}$  and gamma emitters in activated RPV steel samples - a comparison between calculations and experimental analysis. J Radioanal Nucl Chem 323:399-413
- [13] Leskinen A, Salminen-Paatero S, Gautier C, Rätty A, Tanhua-Tyrkkö M, Fichet P, Kekki T, Zhang W, Bubendorff J, Laporte E, Lambrot G, Brennetot R (2020) Intercomparison exercise on difficult to measure radionuclides in activated steel - statistical analysis of radioanalytical results and activation calculations. J Radioanal Nucl Chem 324:1303-1316
- [14] Leskinen A, Gautier C, Rätty A, Fichet P, Kekki T, Laporte E, Giuliani M, Bubendorff J, Laurila J, Kurhela K, Fichet P, Salminen-Paatero S (accepted May 2021) Intercomparison exercise on difficult to measure radionuclides in activated concrete - statistical analysis and comparison with activation calculations. J Radioanal Nucl Chem
- [15] A. Rätty et al., Validation and Optimization of Activity Estimates of the FiR1 TRIGA Research Reactor Biological Shield Concrete, Nuclear Science and Engineering (in review, submitted in July 2021)
- [16] Fortum Power and Heat Oy. Website: <https://www.fortum.com/loviisaeia>